



Bendix™ VORAD® VS-400

Installation Guide

Bendix™ VORAD® VS-400 System

BW2772 (Formerly VOIG0100)

September 2010

Introduction

Warnings	2
Federal Communications Commission	3
Application Information	4
Installation Tools	5

Space Claim

Forward Looking Radar Dimensions	6
Side Object Detection Dimensions	7-8
Driver Interface Unit Dimensions	9

Mounting Requirements

Forward Looking Radar (FLR)	11-19
Side Object Detection (SOD)	20-21
Driver Interface Unit (DIU)	22-23

Electrical Requirements

Forward Looking Radar (FLR)	24
Power Requirements	24
Wiring Schematic	24
Wiring Harness	25
Ignition and Ground	26
J1939	27
Side Object Detection (SOD)	28
Power Requirements	28
Wiring Schematics	28
Ignition and Ground	29
Driver Interface Unit (DIU)	30
Power Requirements	30
Wiring Schematics	30
Wiring Harness	31
Ignition and Ground	32
J1939	33
Optional I/O	34

Final Test

Final Test	35
----------------------	----

Appendix

Retrofit Information	36
J1939/11 Data Link Detail	38
SAE J1939/11 Recommended Cable Termination Procedure	39
SAE J1939/11 Recommended Cable Splice Procedure	40
J1939/15 (lite) Data Link Detail	41
Wiring Schematics	42
SmartCruise and/or Collision Warning System	43
Collision Warning System with Side Object Detection	44
Connector Pin Descriptions	45
Vendor Contact Information	47

Warnings and Cautions



Improper use of this system could lead to a serious accident. Read this entire Installation Guide before operating the Bendix™ VORAD® VS-400 system. Pay particular attention to the safety messages below. This manual should be used in conjunction with proper training.

Limitations of Collision Warning Systems

The Bendix™ VORAD® VS-400 collision warning system is intended solely as an aid for an alert and conscientious professional driver. It is not to be used or relied upon to operate a vehicle. The system should be used in conjunction with rear view mirrors and other instrumentation to maintain safe operation of the vehicle, ground personnel, and adjacent property. A vehicle equipped with the Bendix™ VORAD® VS-400 system should be operated in the same safe manner as if the system were not installed. The system is not a substitute for normal safe driving procedures. It will not compensate for any driver impairment, such as drugs, alcohol, or fatigue. Should the system become inoperative, it could jeopardize the safety or lives of those who depend on the system for safety.



The system will not sense objects if the sensor view is obstructed. Therefore, do not place objects in front of the system sensor. Remove heavy buildups of mud, dirt, ice, and other materials.

Proper alignment is critical to correct operation of the system.

Testing and inspection of the system in accordance with these instructions and record of the results should be listed on the daily maintenance report. The units on operating vehicles must be tested each day (see the “Testing and Maintenance” section) prior to the vehicle’s operation. Results of this test must be recorded in the maintenance log.

People operating this equipment **MUST** check for proper operation at the beginning of every shift or safety inspection period.



People’s lives depend on the proper installation of this product in conformance with these instructions. It is necessary to read, understand, and follow all instructions shipped with the product.

Failure to follow all safety precautions and instructions may result in property damage, serious injury, or death.

The Bendix™ VORAD® VS-400 system is intended for commercial use. Proper installation of a backup aid requires a good understanding of truck electrical systems and procedures, along with proficiency in the installation.

Store these instructions in a safe place and refer to them when maintaining and/or reinstalling the product.

Federal Communications Commission

This device complies with Part 15 of the FCC (Federal Communications Commission) rules. Operation is subject to the following two conditions: (1) This device may not cause harmful interference and (2) this device must be able to accept any interference received, including interference that may cause undesired operation. Any interference that may be caused should be reported to the local FCC field office or to the Federal Communications Commission; Enforcement Bureau; 445 12th Street S.W.; Room 7-C485; Washington, DC 20054.

Any changes or modifications made by the user to this equipment that are not expressly approved by Bendix Commercial Vehicle Systems LLC could void the user's authority to operate the equipment.

Every effort has been made to ensure the accuracy of all information in this brochure. However, Bendix Commercial Vehicle Systems LLC makes no expressed or implied warranty or representation based on the enclosed information. Errors or omissions should be reported to: Bendix Commercial Vehicle Systems LLC, 901 Cleveland Street, Elyria, OH 44035 or 1-800-AIR-BRAKE (1-800-247-2725).

Application Information

Function	Driver Interface Unit (DIU) and Forward Looking Radar (FLR)		Side Object Detection System
	FLR	DIU	SOD
S/C Only	X	X	
CWS Only	X	X	
S/C & CWS	X	X	
S/C, CWS & SOD	X	X	X
SOD Only			X

S/C = Bendix™ SmartCruise® adaptive cruise control

CWS = Collision Warning System

Installation Tools

Recommended Tools

- Forward Looking Radar Alignment Tools - Digital Level and 4'-6' Straight Edge
- PC-Based Service Tool - ServiceRanger - TCMT-0070B
- Basic Hand Tools

Reference Literature

- Installation Guide - BW2772
- Troubleshooting Guide - BW2771
- Driver Instructions - BW2769

Reference Drawings

- Side Object Detection System Display - 15670-001 Installation Drawing
- Side Object Detection System Sensor - 15671-001 Installation Drawing
- Side Object Detection System Harness - 15672-001 Installation Drawing
- Forward Looking Radar - VSFR-001 Installation Drawing
- Driver Interface Unit - VSDI-001 Installation Drawing

For more information within the U.S., Canada, and Mexico call 1-800-AIR-BRAKE (1-800-247-2725), or contact a local OEM dealer.

Space Claim

Forward Looking Radar Dimensions

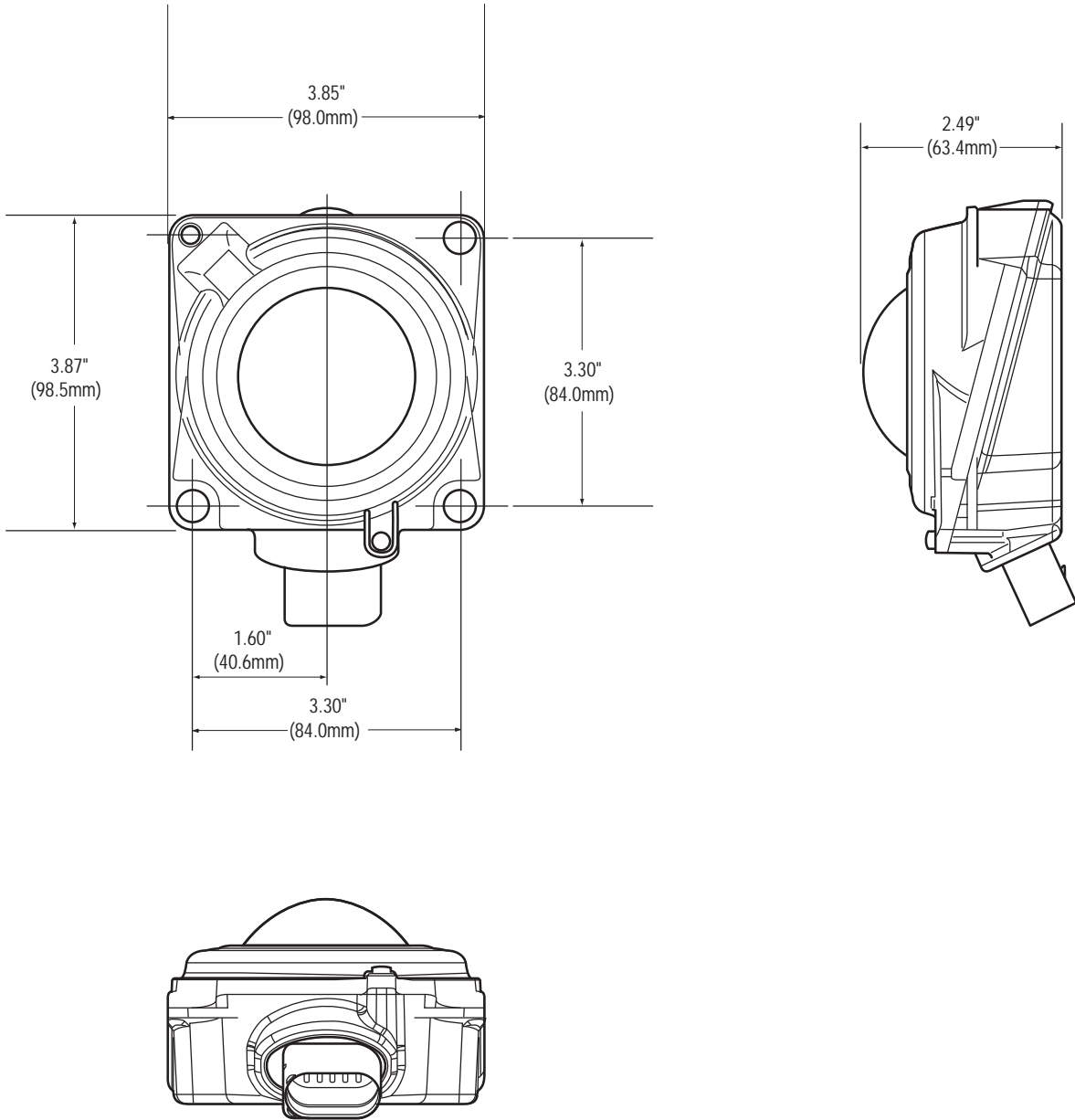

Side Object Detection Dimensions

Side Sensor

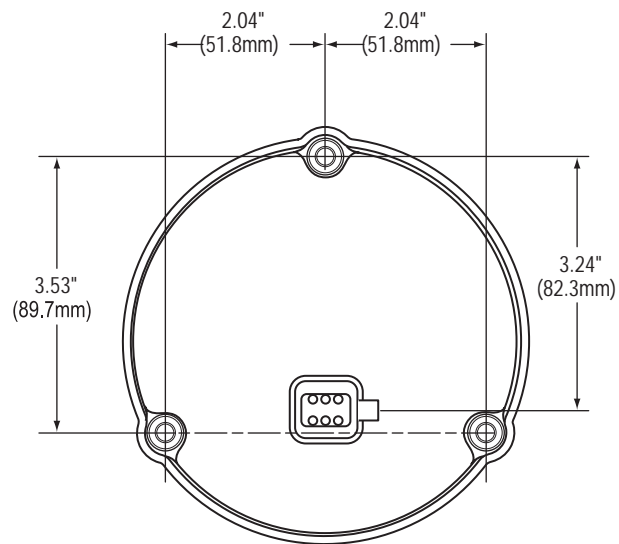
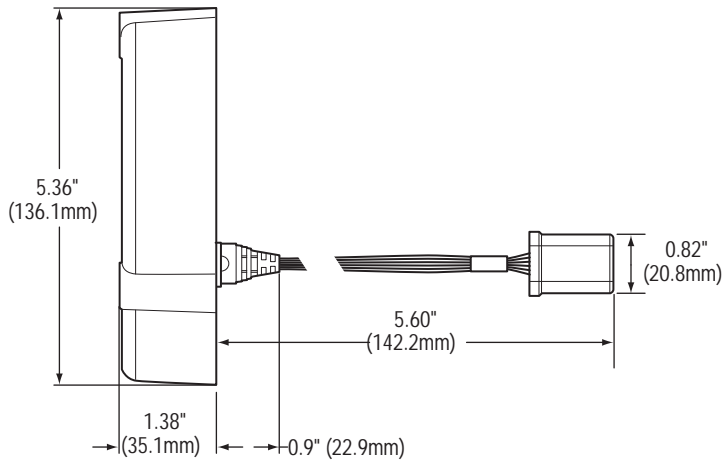

Space Claim

Side Sensor Display

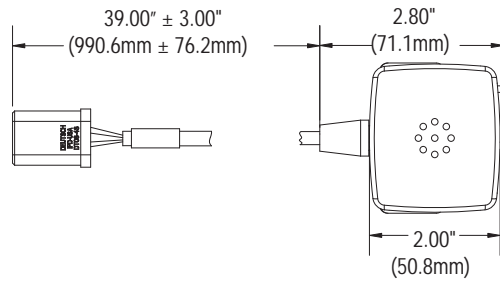
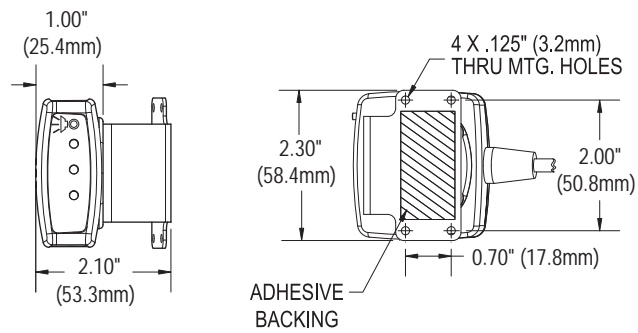
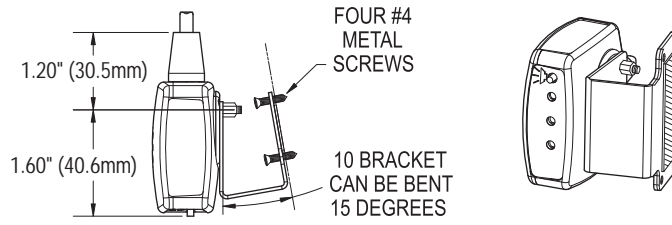

Driver Interface Unit Dimensions

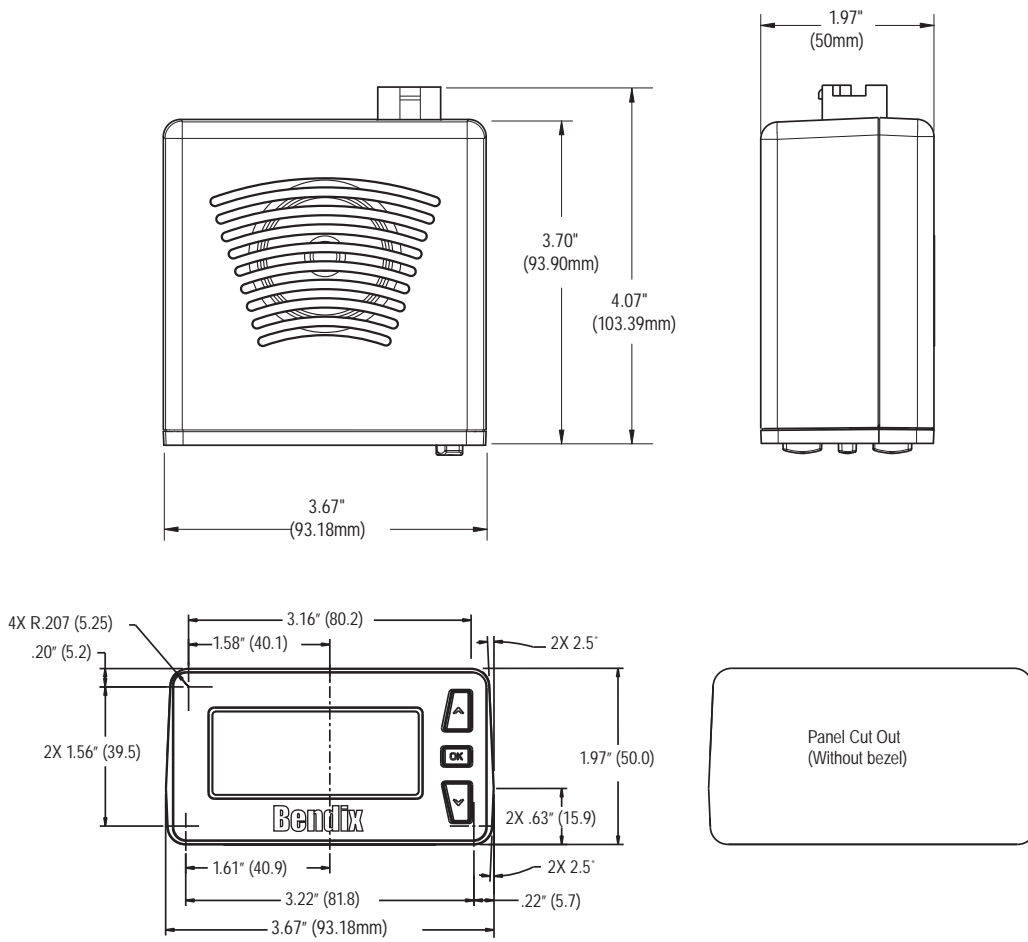

Mounting Requirements

Overview

The installation of the Bendix™ VORAD® VS-400 System is intended to cover a wide range of commercial vehicle applications. This publication is intended to be a reference for commercial vehicle installations using the vehicle's SAE J1939 data link interface. For vehicles without a SAE J1939 data link, some installation procedures may vary for a proper system installation and operation.

Typical Component Locations

Note: Not all components are required for every application.

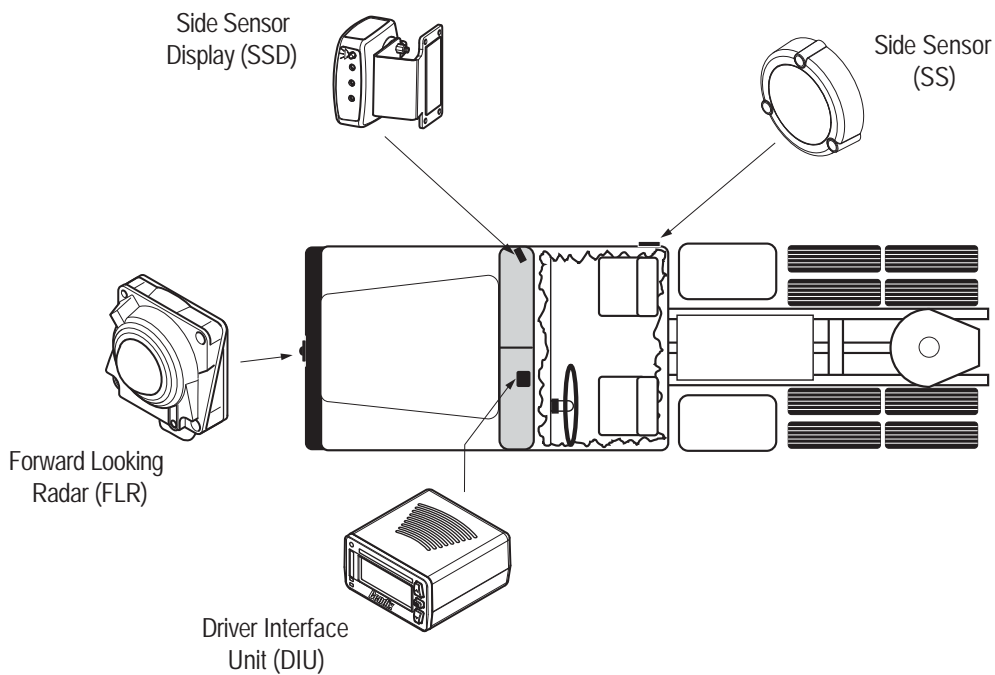

Mounting Requirements - Forward Looking Radar (FLR)

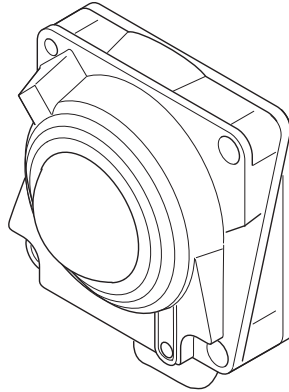

The Forward Looking Radar (FLR) determines the distance, lane position (azimuth), relative speed (velocity), and direction of vehicles in front of the host vehicle. The FLR is a Doppler radar that transmits at a 77 GHz frequency. A built-in yaw rate sensor (gyro) provides relative azimuth for lane positioning in turns. The SAE J1939 interface allows the FLR to be installed as a Bendix™ SmartCruise™ adaptive cruise control only stand-alone unit, or as a component of the complete Bendix™ VORAD® VS-400 System.

The FLR can track multiple objects simultaneously in relative motion within the radar's effective range of view. Relative motion is defined as an object's movement towards, or away from, the radar transceiver.

Note: The Forward Looking Radar is only activated while the vehicle is in motion.

Mounting Orientation

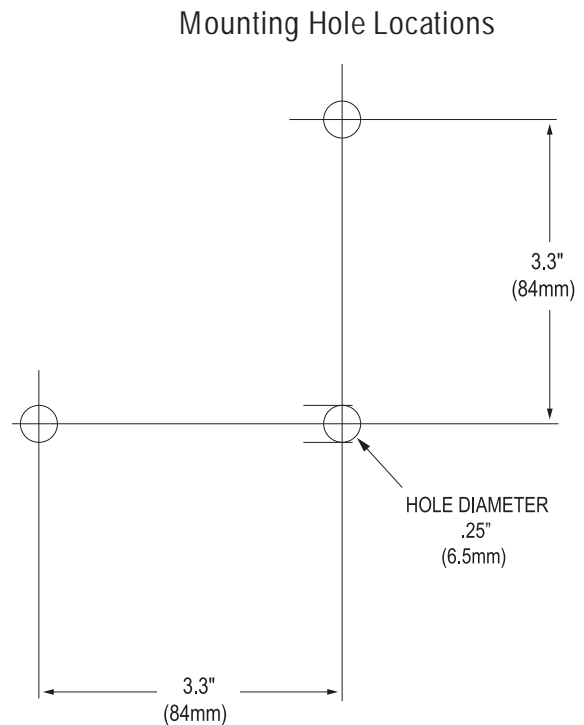
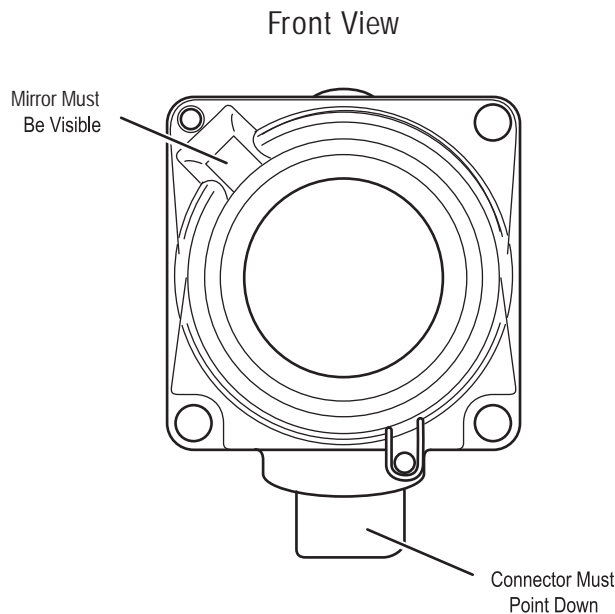

Mounting Requirements

Installation

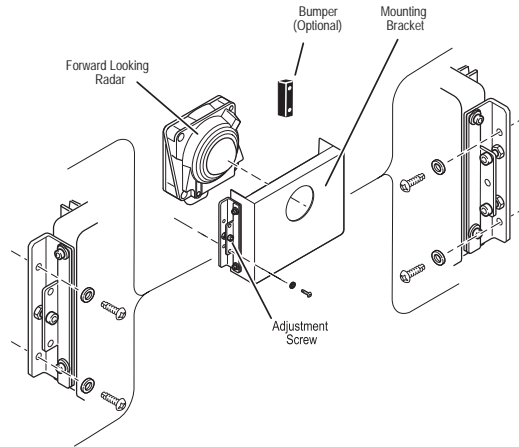

Note: The design of the Mounting Bracket may vary. This is a typical representation.

Located on the forward most position of the vehicle, the FLR transmits and receives low power, high frequency electromagnetic energy. Transmitted energy that is reflected off objects in front of the vehicle is received and processed by the radar's internal microprocessor to determine the object(s) relative distance, position (azimuth), speed (velocity), and direction of travel.

For proper operation, the 77GHz forward looking radar unit shall be installed on the vehicle with the following constraints:

- The radar unit must be rigidly attached to the forward most position of the vehicle chassis, perpendicular with the vehicle's forward thrust axis.
- The lateral position of the radar should be located as close to the vehicle's center as possible (+/- 50mm).
- The vertical position of the radar must be at a minimum of 12" (304.8mm) and a maximum of 28" (711.2mm) from the ground.
- The radar must be installed in a manner that protects it from minor frontal impacts, as well as protecting the radar's harness connector from road debris.
- The mounting hardware must allow for a minimum of $\pm 3^\circ$ mechanical adjustment of the radar's horizontal and vertical axis.
- The radar must be orientated so the harness connector is pointing in the downward position.

The mounting location must provide a clear view in front of the radar. Ideally, the radar will be recessed behind the profile of the vehicle's front bumper or grill, but not to interfere with the radar's sight profile. See "No Radar Obstruction Zone" on next page.

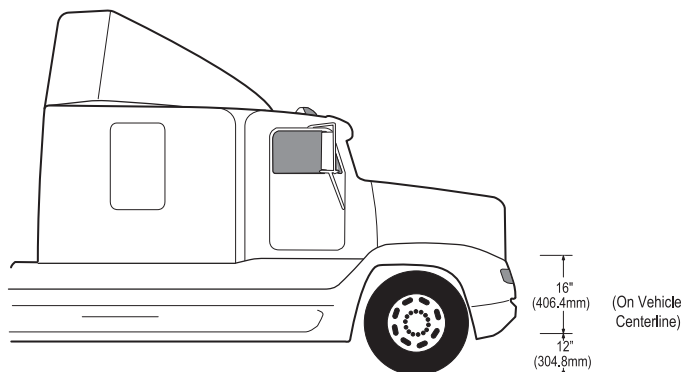

Requirements

The Forward Looking Radar can be mounted on the front of the vehicle, or integrated behind a non-metallic body panel as long as the mounting, alignment, and material requirements are met in the following sections.

Field of View Definition

The Forward Looking Radar (FLR) field of view in elevation and azimuth is illustrated below. The grey area represents a cross-cut view of the three-dimensional "No Radar Obstruction Zone".

Using the illustration below, the diameter of the hole in front of the Forward Looking Radar can be determined. For materials within 30mm of the FLR, the hole diameter must be greater than 70mm. For materials 40mm from the front of the FLR, the hole diameter must be greater than 90mm.



Any hole diameter less than the required size, will effect a clear line of sight for the FLR unit.

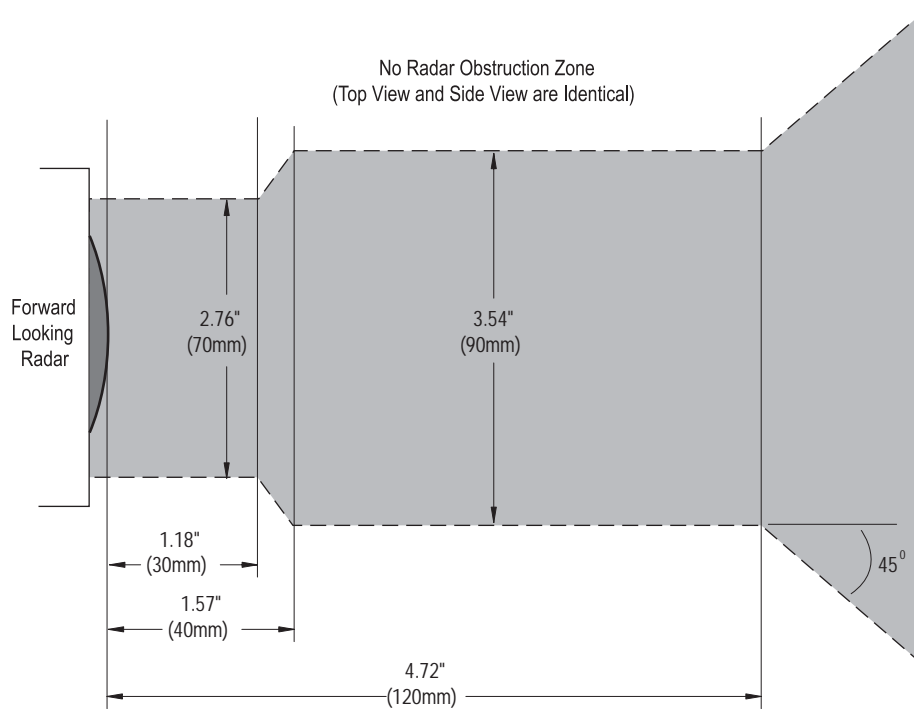

Cover Material Requirements

Any material that may be located in the Forward Looking Radar's field of view (including bumpers, spoilers, etc.) can not be made out of any metallic material or have any carbon content. It is recommended that any material that will be located in the FLR field of view be approved by Bendix Commercial Vehicle Systems prior to use.

If the radar has a cover perpendicular to the radar beam, even a very slight vibration of the cover can cause the reflected radar signal to be seen as a very strong false target at close range. If the radar cover is not perpendicular by more than 5° then the returned reflection does not enter the receiver channel and hence is not detected. The recommended angle of the beam to the cover is 50° to 80° . There have been applications that have the cover perpendicular, but the forward radar and the cover were directly mounted to each other to minimize the cover's movement to the radar module. This may be a difficult condition to maintain.

The cover must not contain any metal or high carbon concentrations, as this reduces the radar range. The electrical characteristics of the cover material (on microwave RF) and its thickness can effect the range as well. Polymeric or ceramic material is recommended. Recommended thickness are based on the cover's angle. The table on the following page lists material thicknesses for a perpendicular or 80° angle cover. The ideal thickness also depends on the angle of incidence of the cover relative to the radar beam axis. The materials in this table do not represent the only possible make up for a cover.

The recommendation scoring system has been applied as follows:

- Losses shall be less than 0.7dB.
- Thickness for rigidity reasons shall be greater than 2mm.

Thickness accuracy: +/- 0.15mm

Thickness recommendation is based on cover being a flat unpainted surface that extends beyond the "No Radar Obstruction Zone" (see previous page). Since paints can impact the losses, they need to be evaluated separately. As with the cover, the paint must not contain metal or carbon.

- The thickness depends on the angle of incidence of the bumper shield located in the radar field view relative to the radar beam axis; it should be updated with the real angle.
- The angle of incidence is recommended to be between 50° to 80° ; 90° is prohibited so as to avoid any spurious reflection of the radar beam back into the Forward Looking Radar.

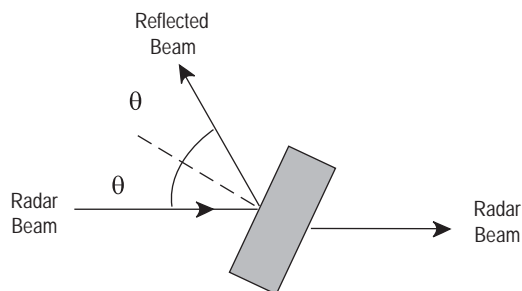

- Painting can induce extra losses that depend heavily on the painting thickness itself and on its painting process. These paints need to be tested individually to assess their impact on the recommendations made in this document. For more information, see the "Painting" section of this publication.

Mounting Requirements

Options in white boxes are considered good options.
Options in grey boxes are considered possible options.

Material Number	Commercial Reference*	Recommended Material Thickness (mm)	Recommended Material Thickness with Cover @ 80° (mm)
1	Polyloy B69L62 PA6 TUC1228/93	2.25	2.22
2	CYCOLAC XMA TUC1137/94	2.36 3.53	2.32 3.48
3	B70GFE30 TUC308/92	2.1	2.07
4	Hostacom PPX678/2 TUC1617/89	2.38	2.34
5	NORYL PX1112 TUC648/86	2.35 3.53	2.31 3.48
6	Hostaform C9021 TUC2559/83	2.33 3.5	2.29 3.45
7	Hostalen GDPE7255 TUC310/92	2.56 3.84	2.52 3.78
8	Hostacom PPR1042 TUC2641/86	2.51 3.77	2.47 3.71
9	PP-Kienb	2.39 3.58	2.35 3.53
10	ABS-Kienb	2.32	2.28
11	PPN 1080	2.58 3.88	2.54 3.82
12	XENOY POCAN KU (PBT+PC)	2.35	2.31
13	ASA	2.26	
14	PC - 0.1% soot	2.33	2.29
15	TICONA Celanex 2003 GV1/20 (PBT 20% GF)	2.15	2.12
16	TICONA Celanex 2003 GV1/30 (PBT 30% GF)	2.05	2.02
17	GE Plastics NORYL PPX630 (PPE + PP 30% GF)	2.4	2.36
18	GE Plastics NORYL GTX830 (PPE + PA 30% GF)	2.1	2.07
19	Ryton PPS R4-240 Nat PPS 40% GF	2.1	2.07

*Commercial references are from European suppliers for the automotive market.

Vibration Specifications

Mounting mechanisms shall be designed to be compliant with the radar vibration spectrum illustrated below.

These vibration constraints are based on radio-frequency considerations in order to be compliant with the radar functional specification.

There are no specific mechanical requirements along the Y- and Z-axis from a radio-frequency point of view. The mechanical movements measured at the FLR center along the X-axis shall be less than the peak-to-peak displacement shown below.

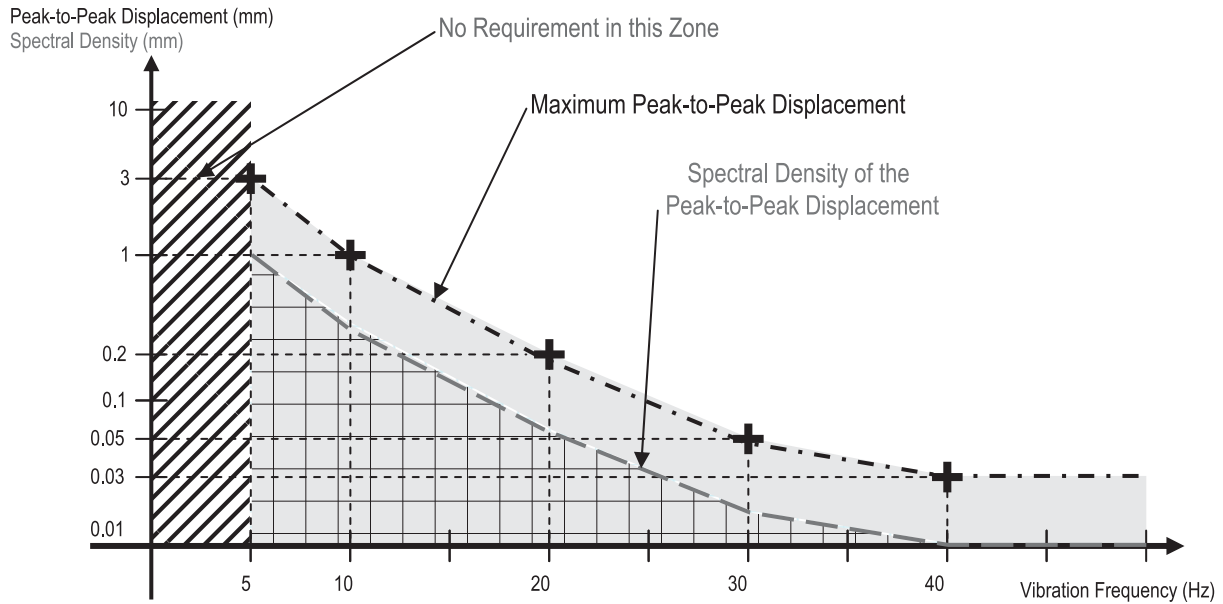

Mechanical movement along the X axis shall be less than:

Note: All values are peak-to-peak.

- 5 Hz < 3 mm
- 10 Hz < 1 mm
- 20 Hz < 0.2 mm
- 30 Hz < 0.05 mm
- Above 40 Hz < 0.03 mm

The spectral density of the peak-to-peak displacement shown above should be measured over 50ms. Also, the spectral density of the peak-to-peak displacement shall be less than the above-mentioned values divided by 3.

Painting

A wide variety of colors and textures can be applied to the Forward Looking Radar housing using commercially available organic paints and conventional application processes.

Painting the component may assist with color degradation over time.

The following guidelines apply:

- Paints must not contain metal or carbon particles.
- Carbon content of paint could be a factor as high concentrations could reduce transparency.
- Paint thickness may impact the radar's ability to pass through the surface.
- It is not recommended to paint the lens area.
- Do not paint the FLR mirror.
- Do not paint the mounting points as it could cause incorrect bracket engagement.
- Protect the connector breather element during any painting operation.

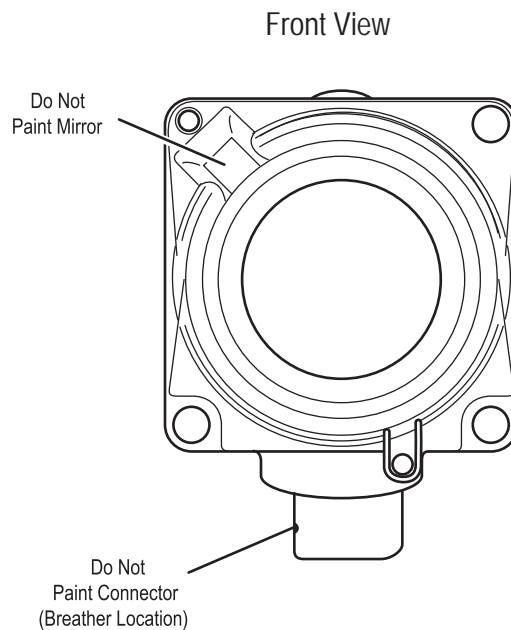

Alignment



The alignment of the Forward Looking Radar is critical to the correct operation of the Bendix™ VORAD® VS-400 system. Improper alignment can cause the system to improperly detect objects in the vehicle's path. Every precaution should be taken to ensure the VS-400 alignment (both horizontal and vertical), is correct.

Alignment of the Forward Looking Radar is a repetitive process of adjusting the vertical and horizontal axis using the bracket screws.

Note: The vehicle must be parked on a level surface. If the vehicle is on an angled surface, then level compensations must be made to ensure proper alignment.

Below are steps for a typical alignment procedure. Other companies, such as Hunter Engineering Company (11250 Hunter Drive, Bridgeton, MO 63044, 314-731-3020), can also be contacted to establish alignment using professional alignment equipment.

Vertical Alignment

The steps for vertical alignment are as follows:

1. Hold a digital level against the flat surface of the mounting bracket.
2. Use a 5/32" Allen wrench to loosen the locking screws.

Note: Failure to loosen both locking screws will result in damage to the alignment bracket.

3. Adjust the alignment screws until the digital level reads down $0^\circ \pm .2^\circ$.
4. Once aligned, tighten the locking screws.

Note: The illustration below shows a typical mounting and mounting bracket. The design may vary.

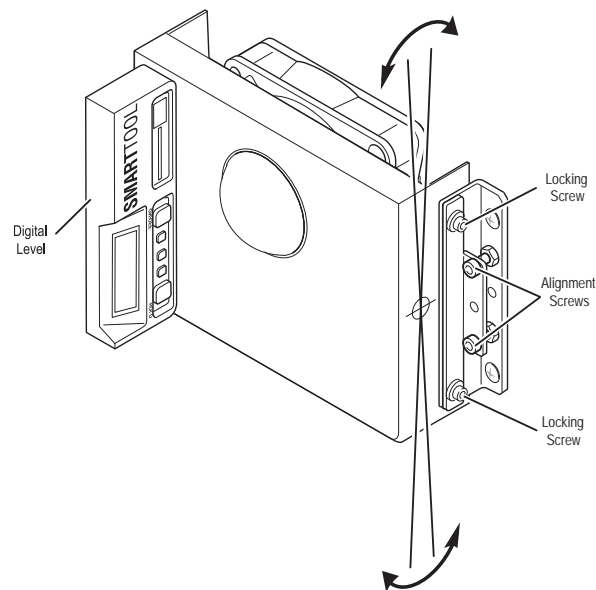

Horizontal Alignment

The Forward Looking Radar must be facing straight ahead (azimuth) of the vehicle in order to optimally detect objects in the vehicle path.

1. Select two truck reference points that are identical and symmetrical about the truck centerline. Ensure the reference points are equally aligned. Items such as fenders and headlights should not be damaged or distorted, otherwise, the alignment will be inaccurate.
2. Center a 4'-6' (1-2m) straight edge across a flat surface of the Forward Looking Radar bracket.
3. Measure the distance between the reference points and the face of the straight edge.
4. Use a 5/32" Allen wrench to loosen the locking screws.

Note: Failure to loosen both locking screws will result in damage to the alignment bracket.

5. Adjust the alignment screw until the two measurement points are equal within $\pm .1"$ (2.54mm).
6. Once the measurements are equal for both of the reference points, tighten the locking screws.
7. Check both the vertical and horizontal alignment:
 - a. Re-measure the reference points to ensure they are equal.
 - b. Use the digital level to verify the vertical alignment is still face down 0° from vertical $\pm .2^\circ$.

Note: The illustration below shows a typical mounting and mounting bracket. The design may vary.

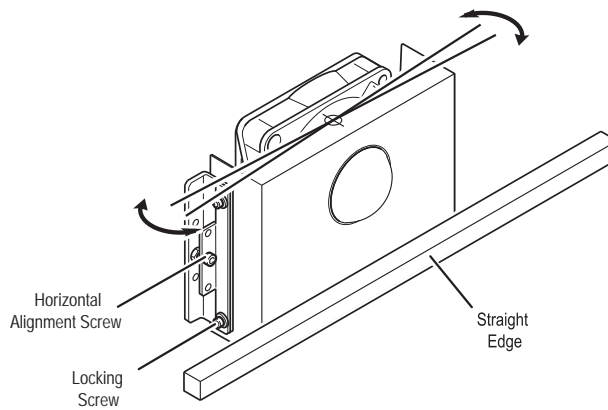

Mounting Requirements - Side Object Detection (SOD)



Side Sensor

The Side Sensor should be mounted on the side of the vehicle, between 22" (558.8mm) and 36" (914.4mm) from the ground and at least 18" (457.2mm) rear of the side view mirror (see diagram below). Typically, the Side Sensor is located on the passenger side of the vehicle, however, it can also be installed on the driver side of the vehicle.

Note: To reduce the possibility of the sensor detecting objects mounted to the vehicle like the steps or fuel tanks, make sure the face of the sensor extends out a minimum of 5/16" (7.9mm) further than any other object within 6" (152.4mm) of the sensor's body.



Failure to mount Side Sensor properly will result in a solid red light indicating a constant detect mode. This is critical to the correct operation of the VS-400 system.

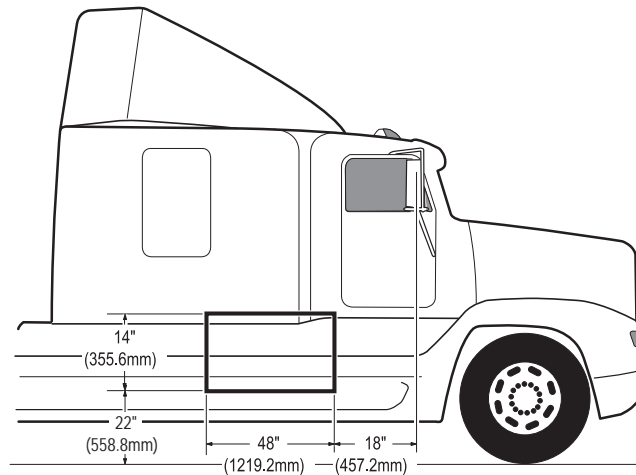

Mounting Requirements

Sensor Orientation

The Side Sensor should be orientated so the embossed logo is parallel to the ground. Orientation is crucial for proper operation due to the radar's polarized beam profile.

Mounting the Sensor

The sensor should be mounted to the vehicle using 10-24 (6mm) stainless steel hardware. Bolts should be installed from the sensor side, with flat washers and nylock nuts on the backside. Torque hardware to a maximum of 22 lbs. in. (2.5 Nm). Do not over torque.

CAUTION

Failure to observe torque setting will result in a damaged or cracked sensor and result in a void of warranty.

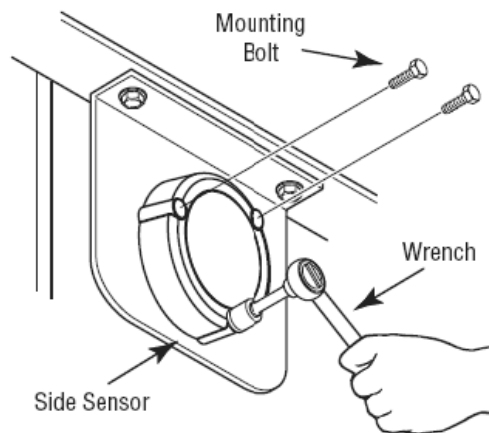

Side Sensor Display

The Side Sensor Display (SSD) should be mounted on the inside of the cab to the windshield pillar. The display unit should be positioned in line with the side view mirror on the same side of the vehicle as the sensor without obstructing the driver's view.

WARNING

The Side Sensor Display is not weather proof and must be mounted on the inside of the cab. Failure to observe this warning will result in a void of warranty.

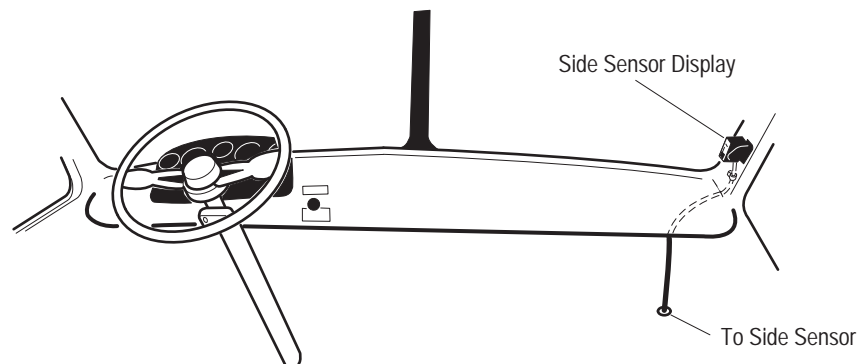

Vehicles with dual left and right side sensors will have a display mounted on both the left and right windshield pillars.

Mounting Requirements - Driver Interface Unit (DIU)

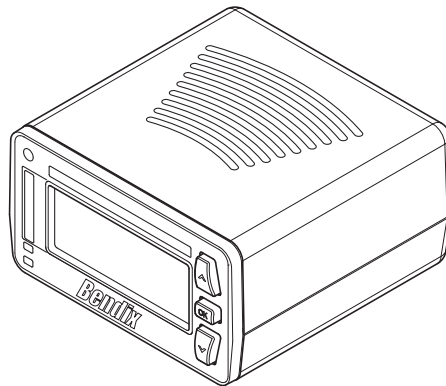

The Driver Interface Unit (DIU) serves as the Bendix™ VORAD® Collision Warning System's central information center. The DIU provides the driver with visual and audible alerts, as well as system configuration, status, and diagnostic information. The DIU uses the vehicle's SAE J1939 data link to communicate with the FLR, and other vehicle system devices.

Mounting Orientation

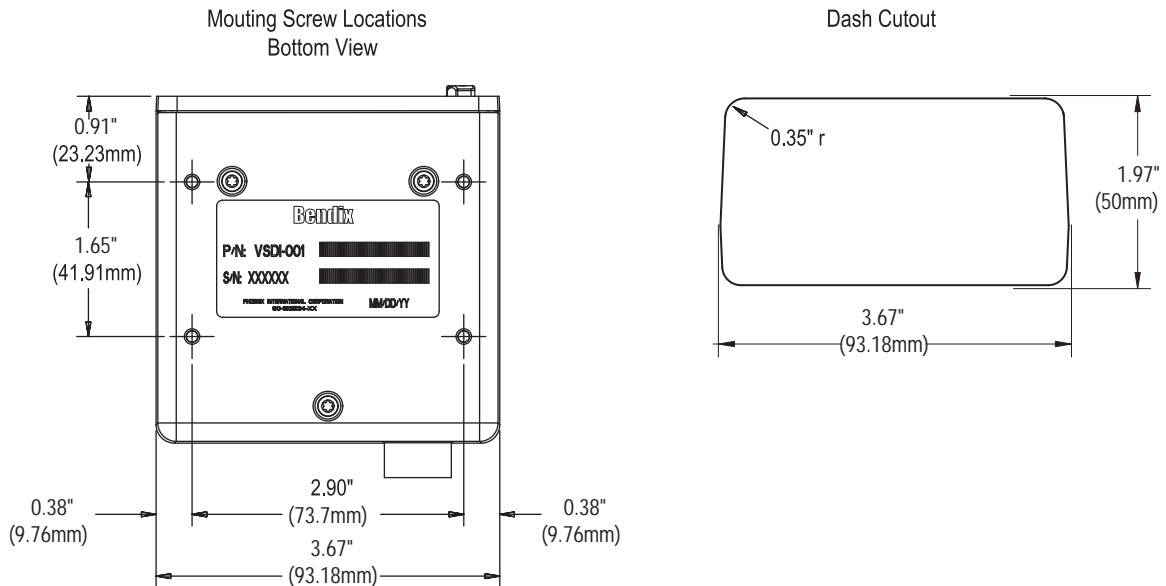

Torque Specification

Recommended mounting screws #6x19 Plastite thread forming screw, 3/8" (9.52mm) long. Torque mounting screw to 7 lbs. in. ± 0.7 (0.79N·m ± 0.08) maximum.

Installation

The DIU should be located where the driver can easily view and adjust the controls. This can be located on top of, or integrated into, the dashboard flush with the front edge of the dashboard. Ease of operation and visibility of the DIU front panel are the primary considerations. The method chosen for routing the wiring harness to the DIU should also be taken into consideration when determining the optimal location.

Installation involves mounting the DIU to an in-dash or on-dash bracket. Attach the bottom of the DIU to the bracket with #6-19 Plastite screws. The four mounting screw locations on the display are .393" (10mm) deep maximum. The screws should leave about .060" (1.5mm) minimum of clearance between the tip and the bottom of the hole when installed. For example, a .375" (9.5mm) long screw with a .060" (1.5mm) thick bracket would be acceptable.

Suggested Mounting Brackets

In Dash Installation:

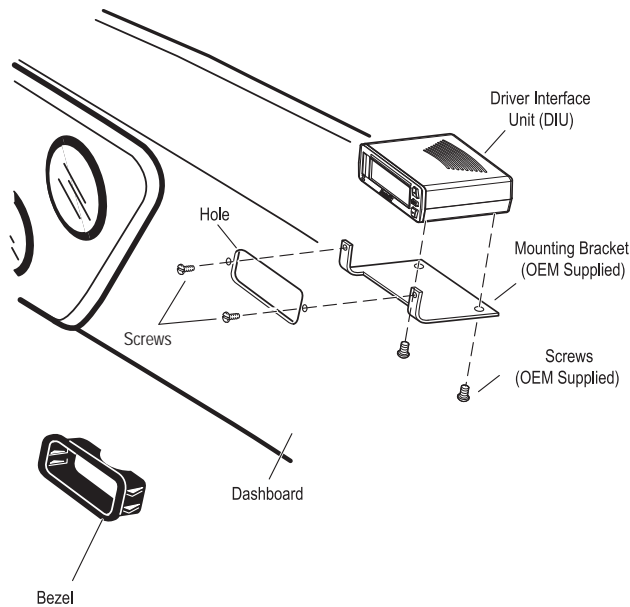

On Dash Installation:

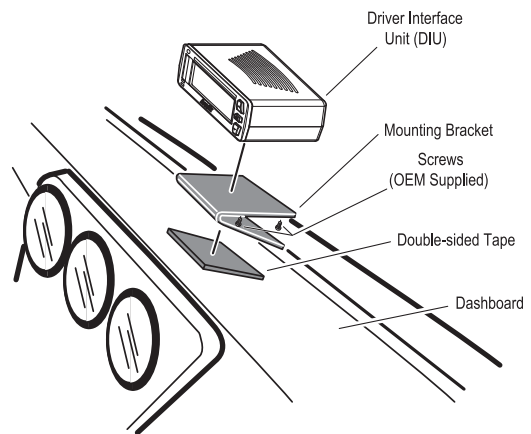

Electrical Requirements - Forward Looking Radar (FLR)

Power Requirements

- Operating Voltage: +9-16Vdc
- Power Current: < 2 amps (average 1 amp)
- Recommended Fuse: 5 amp delayed fuse

Wiring Schematic

All electrical connections can be made in the engine compartment.

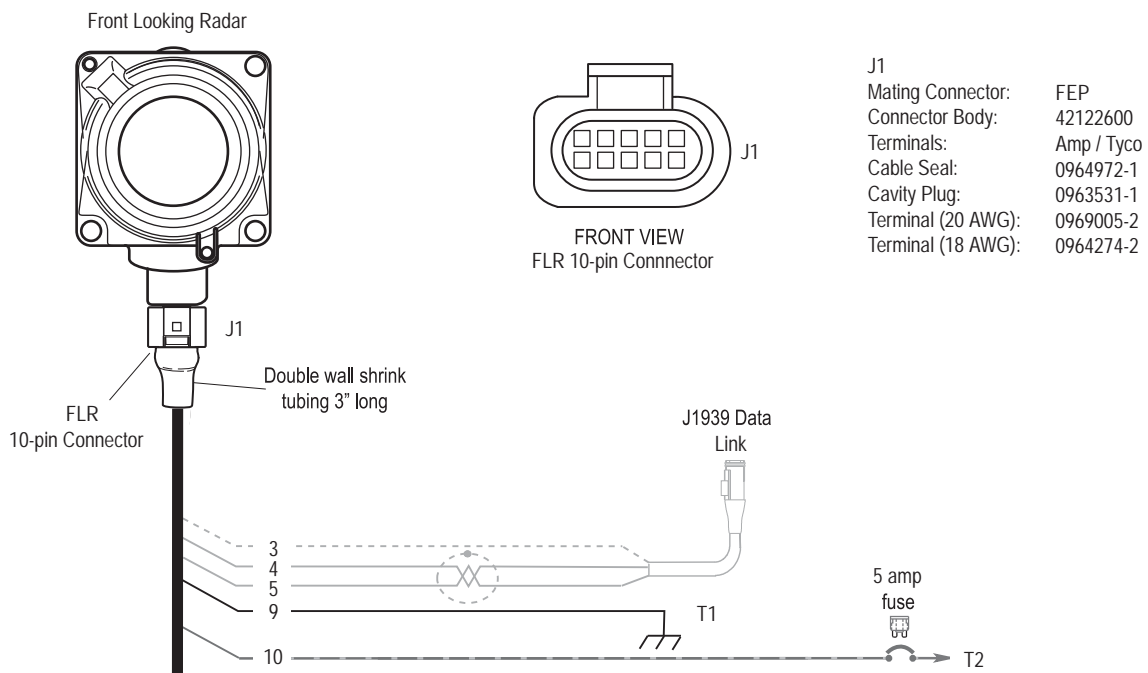

Wiring Harness

Forward Looking Radar

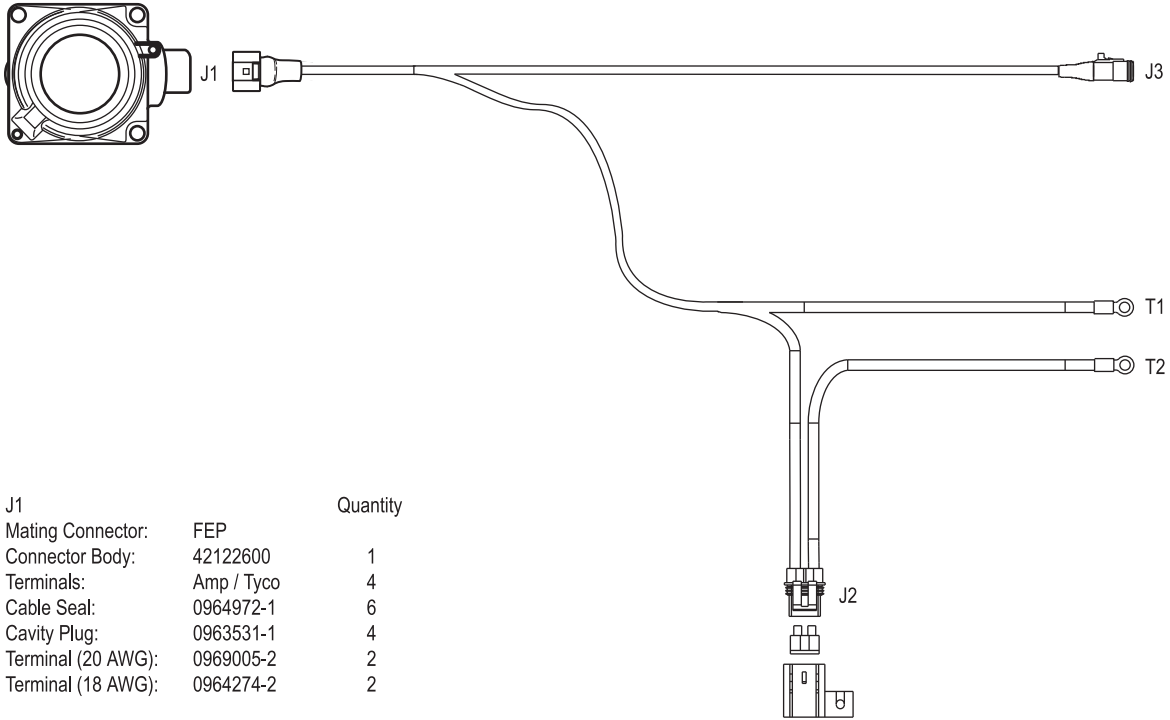

J1		Quantity
Mating Connector:	FEP	
Connector Body:	42122600	1
Terminals:	Amp / Tyco	4
Cable Seal:	0964972-1	6
Cavity Plug:	0963531-1	4
Terminal (20 AWG):	0969005-2	2
Terminal (18 AWG):	0964274-2	2

J2		Quantity
Mating Connector:	Packard	
Connector Body:	12092449	1
Cover:	12033731	1
Terminal:	12020156	2
5 Amp Fuse:	12004005	1

J3		Quantity
Mating Connector:	Deutsch	
Connector Body:	DTM06-2S	1
Wedge:	WM-2S	1
Socket:	0462-201-20141	2

Notes:

All wires to be cross link TXL or equivalent unless otherwise specified.
Use approved J1939 cable.

Interconnection Table

From	To	Code	Gauge
J1-1	Plug	-	-
J1-2	Plug	-	-
J1-3	Plug	-	-
J1-4	J3-A	Yellow	20 AWG
J1-5	J3-B	Green	20 AWG
J1-6	Plug	-	-

From	To	Code	Gauge
J1-7	Plug	-	-
J1-8	Plug	-	-
J1-9	T1	Ground	18 AWG
J1-10	J2-A	IGN1	18 AWG
J2-B	T2	Ignition	18 AWG

Ignition and Ground

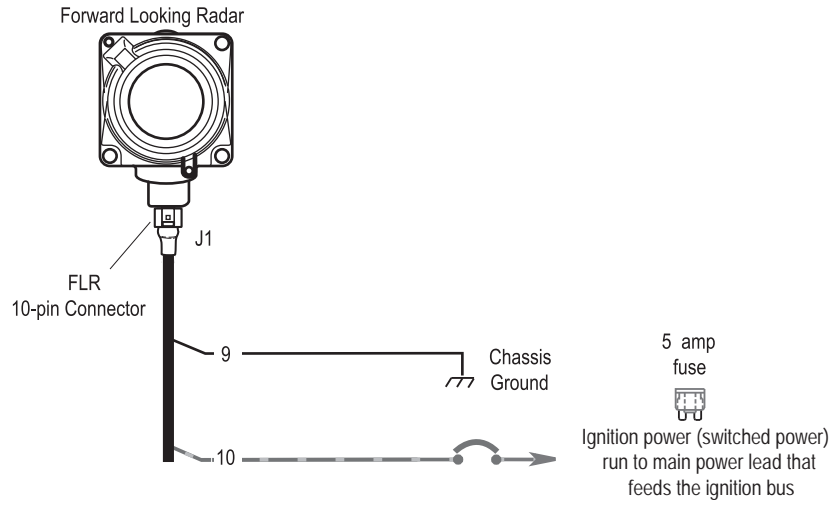

FRONT VIEW
FLR 10-pin Connector

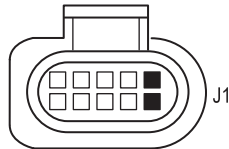

Pin #	Description
J1-9	Chassis Ground
J1-10	+9-16VDC Switched

Electrical Requirements

J1939

Note: The J1939 data bus uses two (2) 120-ohm resistors to terminate each end of the data bus on the vehicle. These resistors must remain in place for proper data bus communication. Due to the mounting location of the Forward Looking Radar, the closest of the vehicle's J1939 terminators may have to be relocated nearer the radar as shown in the diagram below. Check the resistance of the data bus using an ohmmeter before and after adding any device to the bus. With the ignition key in the OFF position, the resistance of the data bus should read approximately 60-ohms (120 / 2).

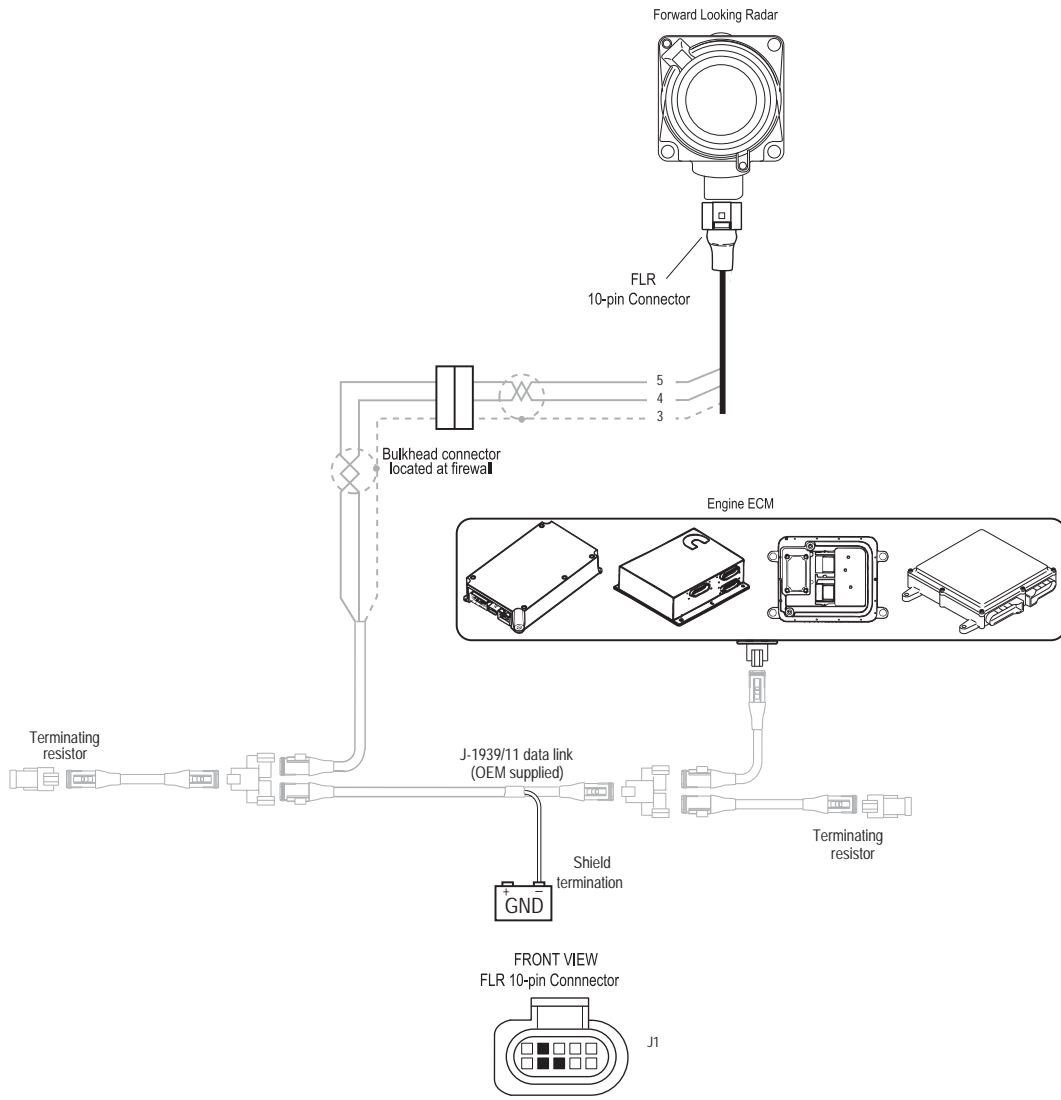

Note: The illustration above shows J1939/11, however J1939/15 (2-wire) can be used.

Pin #	Description
J1-3	J1939_SHIELD
J1-4	CAN_HI
J1-5	CAN_LO

Electrical Requirements - Side Object Detection (SOD)

The Side Object Detection (SOD) system consists of two components: a Side Sensor (SS) and a Side Sensor Display (SSD).

Power Requirements

- Operating Voltage: +9-32Vdc
- Power Current: Not to exceed 0.25 amps
- Recommended Fuse: 1 amp

Wiring Schematics

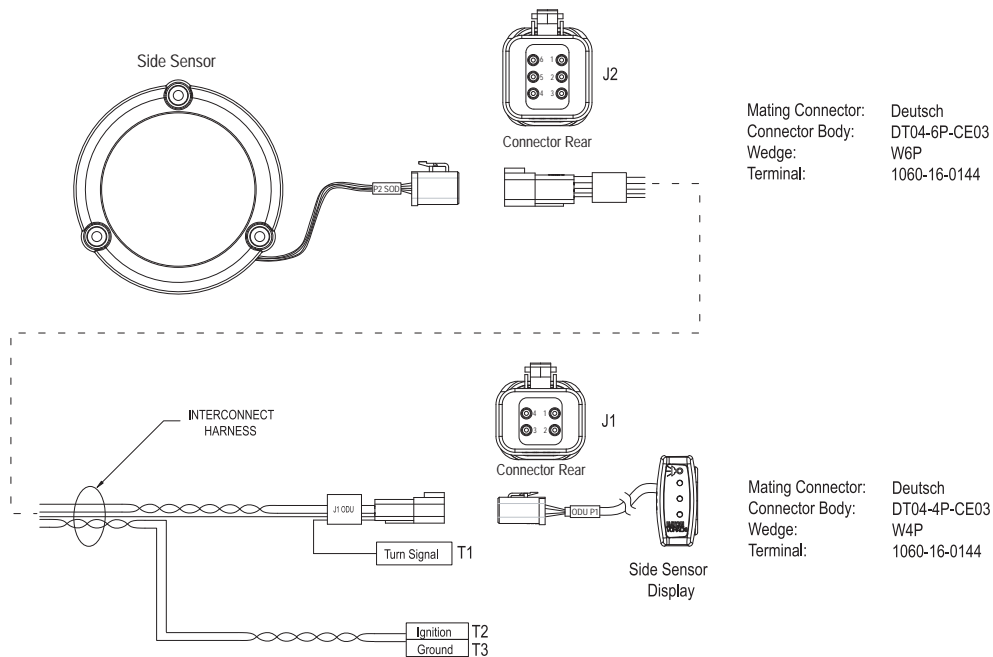

Notes:

All wires to be cross link GXL or equivalent unless otherwise specified.
Use approved J1939 cable.

Interconnection Table

From	To	Code	Gauge
J2-1	T2	Ignition	18 AWG
J2-2	T3	Chassis Ground	18 AWG
J2-3	J1-3	Communication	18 AWG
J2-4	J1-1	Power	18 AWG

From	To	Code	Gauge
J2-5	J1-2	Signal Ground	18 AWG
J2-6	No Connection	-	18 AWG
J1-4	T1	Right Turn Signal*	18 AWG

*For this example, the right turn signal is used, however, the left turn signal could also be used for a Side Sensor installed on the driver side of the vehicle.

Ignition and Ground

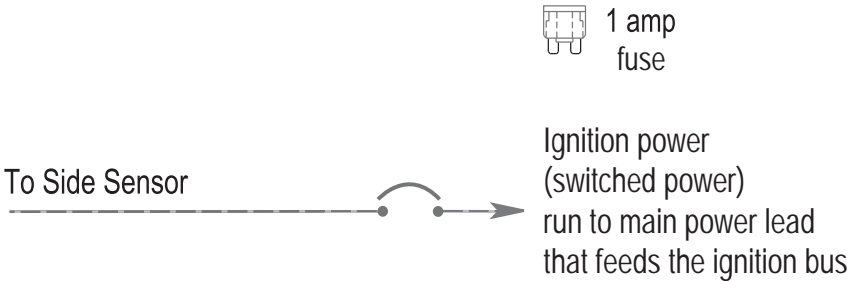
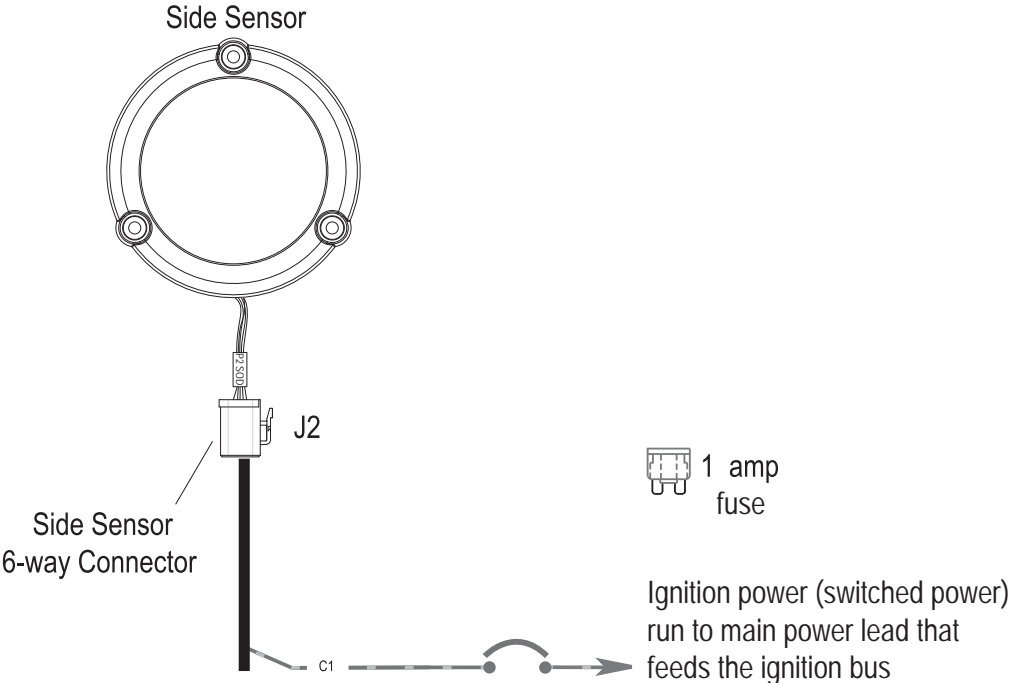

Connector Rear
Side Sensor (6-way Connector)

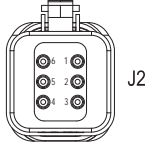

Electrical Requirements - Driver Interface Unit (DIU)

Power Requirements

- Operating Voltage: +9-32Vdc
- Power Current: Not to exceed 2 amps
- Recommended Fuse: 4 amp

Wiring Schematics

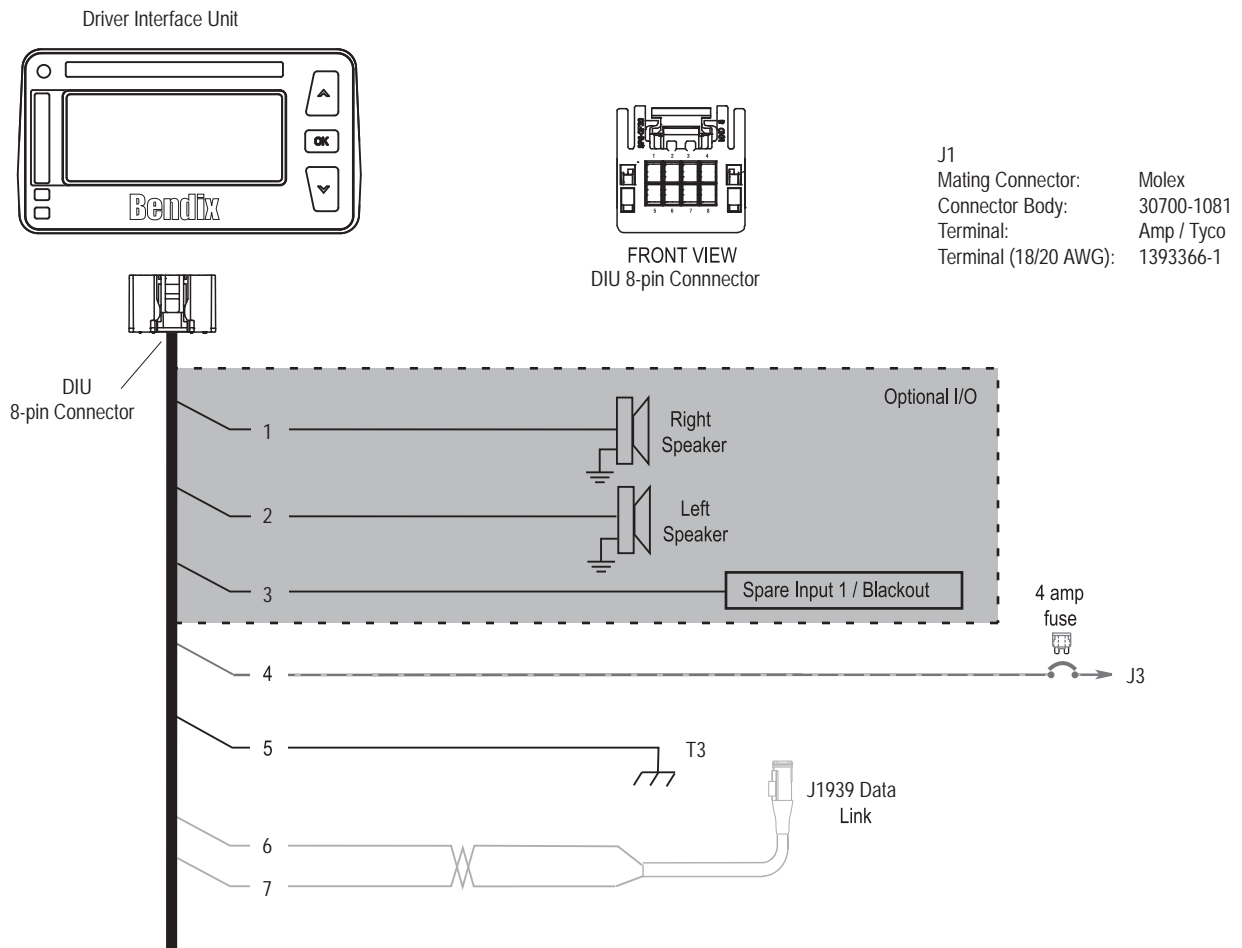

Wiring Harness

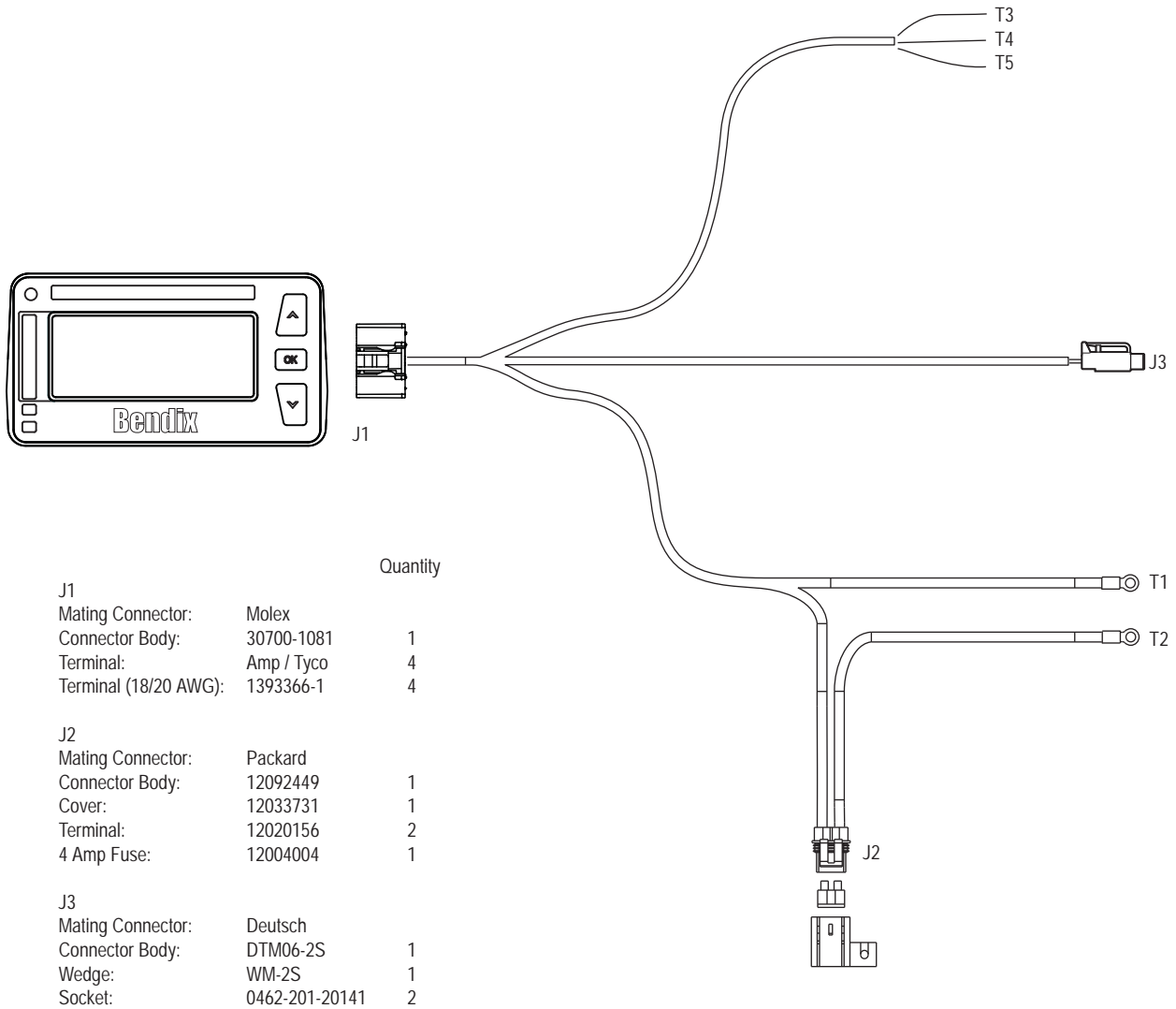

Notes:

All wires to be cross link GXL or equivalent unless otherwise specified.
Use approved J1939 cable.

Interconnection Table

From	To	Code	Gauge
J1-7	J3-A	Yellow	20 AWG
J1-6	J3-B	Green	20 AWG
J1-5	T1	Ground	18 AWG
J1-4	J2-A	IGN1	18 AWG

From	To	Code	Gauge
J2-B	T2	Ignition	18 AWG
J1-1	T3	R-SPK	20 AWG
J1-2	T4	L-SPK	20 AWG
J1-3	T5	Blackout	20 AWG

Ignition and Ground

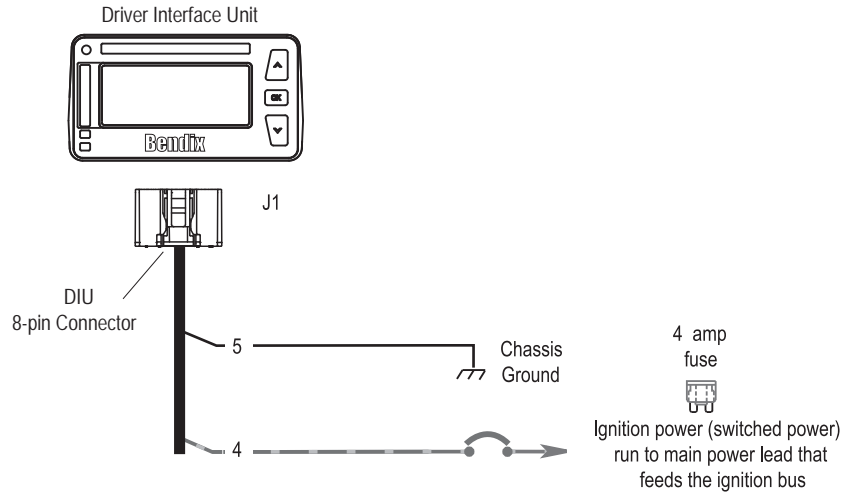

FRONT VIEW
DIU (8-pin Connector)

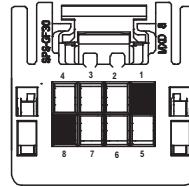

Pin #	Description
J1-4	+9-32VDC Switched
J1-5	Chassis Ground

J1939

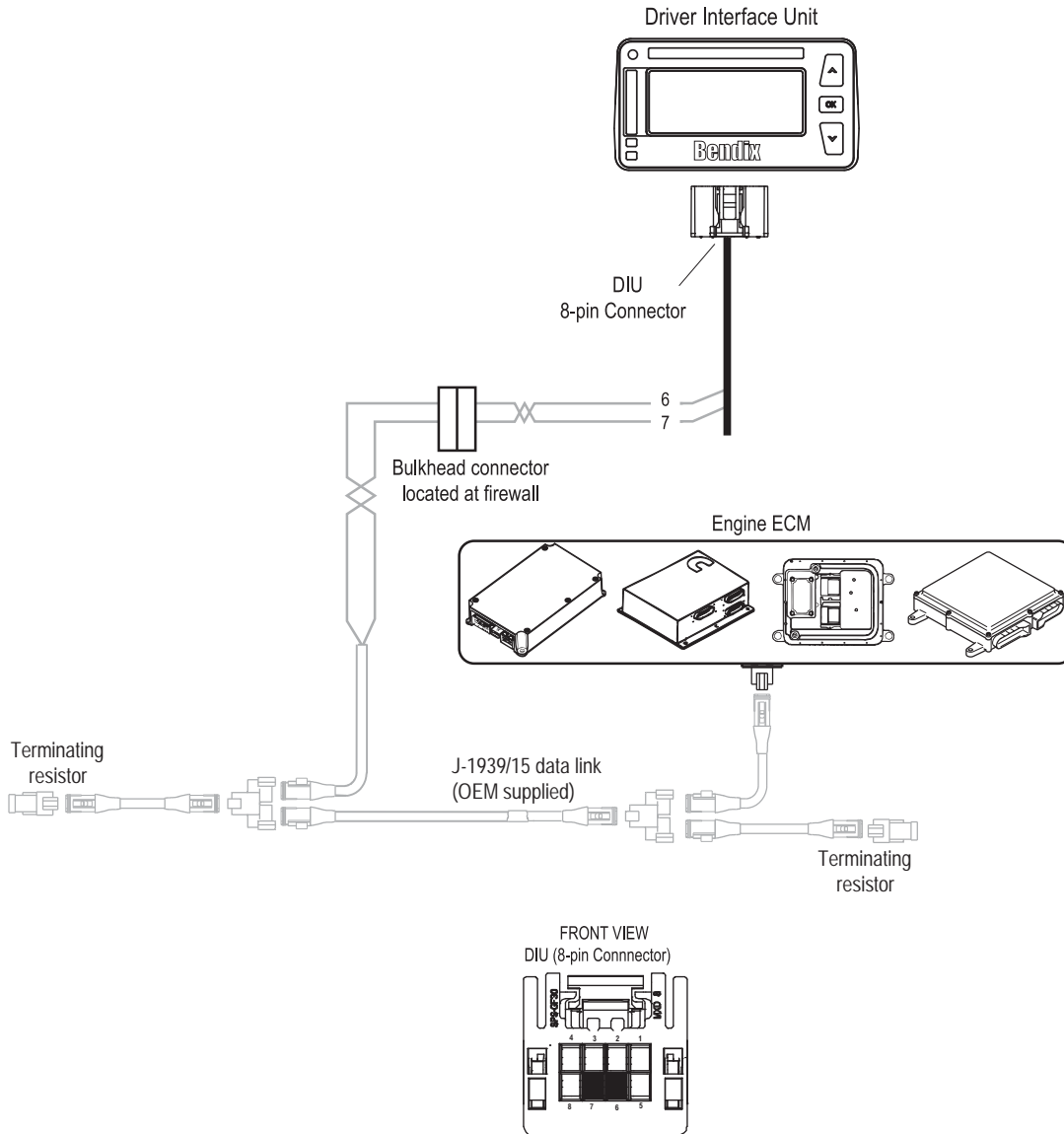

Note: The illustration above shows J1939/11, however J1939/15 (2-wire) can be used.

Pin #	Description
J1-6	J1939-
J1-7	J1939+

Optional I/O

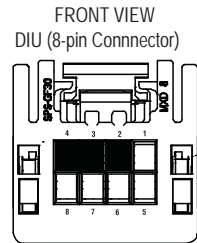
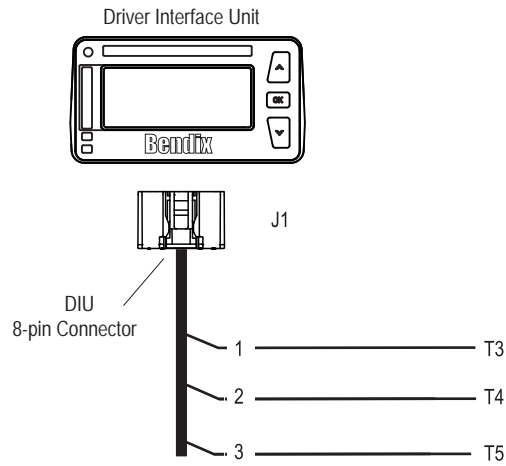

PIN #	WIRE DESCRIPTION	FUNCTION	INPUT / OUTPUT	SOFTWARE REQUIRED
1	R-SPK	Right Speaker	Output - 4 ohm 1 watt	Yes
2	L-SPK	Left Speaker	Output - 4 ohm 1 watt	Yes
3	Blackout	Blackout_Input	Input - Tri-state	Yes

Final Test

Bendix™ VORAD® VS-400 SmartCruise® Adaptive Cruise Control and Collision Warning Functionality Testing		OEM:		
		Chassis S/N:		
		Trans Model:	Trans S/N:	
		Clutch Size/Type:		
		Shift Control S/N:		
	Description	Yes	No	Corrected
Validate SmartCruise® Adaptive Cruise Control Operation and CWS Operation (dyno environment preferred).				
1.	Start truck and verify VS-400 system powers-up (goes through bulb check with no faults indicated).			
2.	Bring truck up to road speed (50-60 MPH suggested).			
3.	Activate cruise control using vehicle controls (set speed switch, lever, button, etc.). Visually inspect DIU for SmartCruise activation notification. Let truck speed stabilize.			
4.	Step on brake. (Truck should deactivate cruise function and coast). Reactivate cruise function. (Truck should accelerate to set speed).			
5.	Step on clutch. (Truck should defuel, coast). Reactivate cruise function.			
6.	Step on accelerator. (Truck should accelerate).			
Dyno Environment				
7.	Resume speed Lower the door to the dyno, or move a reflective target in front of Forward Looking Radar. (15-30 feet away from and directly in front of Forward Looking Radar). While the target is moving in front of radar, the VS-400 should see the target, (indicated by the DIU displaying lights, CWS alerts, LCD screen, and audibles), and the vehicle should defuel and apply the Jake brakes to slow vehicle speed.			
8.	Assuming the above functions performed properly, the vehicle defueled, the target stopped moving (indicated by no target detection in the DIU), the vehicle engine did not drop below 1000 rpm, and the road speed did not drop below minimum requirements, the vehicle should now accelerate back to the set speed on its own.			
9.	If all tests performed and operated as outlined, the Adaptive Cruise Control and CWS functionality test has completed properly, and the Adaptive Cruise Control validation process is complete. Note: Because of the high horsepower engines in use today, and the ability of the Jake brakes to apply twice the braking horsepower to the rear wheels, the truck may defuel to the point the vehicle drops out of Cruise before the target has stopped moving. This moving target, (indicated by the DIU displaying lights, LCD screen, and audibles) would indicate a viable reason to defuel; thereby causing the vehicle to Jake to the point the engine will disengage the cruise function. This is normal and not a deficiency with the system. Note: To test each specific CWS alert requires accurate road speed and target closing distance calculations. Therefore, additional procedures are necessary to facilitate this functionality.			

Retrofit Information

Retrofit Recommended Practices

Body builder electrical systems that are to be interconnected with the VS-400 electrical system should adhere to the latest recommendations of SAE J1292. In addition to SAE J1292, the following recommendations should be followed:

1. All wiring terminals should be properly insulated to prevent "short circuits". All terminals should be of insulation grip design to provide a reliable connection and to prevent terminal fatigue.
2. Terminals and splices that are connected outside the body should be moisture resistant design. Molded insulator for ring terminals should be used. Molded connector/insulators are recommended for use with blade or pin type terminals.
3. Wires must be routed to provide at least 3" (75mm) clearance to moving parts, unless positively fastened or protected by conduit.
4. Wire routing should avoid areas where temperatures exceed 80°C [180°F] and a minimum clearance of 6" (150mm) should be maintained from exhaust system components. Where compliance with this requirement is not possible, heat insulation and heat shields are required.
5. Wire routing and component mounting (switches, relays, etc.) should be located to be easily removed for service. Do not surround the components with body structure that will prevent removal for service.
6. Wiring to all circuit components (switches, relays, etc.) in exposed locations shall provide a drip loop to prevent moisture from being conducted into the device via the wire connection.
7. Routing wiring into wheel splash areas should be avoided. When such routing cannot be avoided, adequate clipping or protective shielding is required to protect wiring from stone and ice damage.
8. Routing wires under the frame side-members or at points lower than the bottom frame flange should be avoided to prevent damage to the wires in off-road operations.
9. The wire retainers and grommets installed by the assembly plant are designed to accommodate only the OEM installed wires. Additional wiring or tubing must be retained by additional clips. When added wires to tubes are routed through sheet metal panels, new holes must be used (with adequate wire protection and sealing).
10. All wiring connections to components of the factory-installed system must be accomplished by using the correct mating wire termination. Connections on studs and ground connections must use ring type terminations.
11. When it is necessary to splice wires, the splice must be adequately crimped to provide a good mechanical and electrical connection. Double wall heat shrink tubing should be used where the outer wall will provide adequate electrical insulation and the inner wall melts and seals the splice from the environment.
12. **Never add another circuit or splice into the ignition or battery power supplies.** The fuses and circuit breakers installed at the assembly plant are designed to protect the wiring and electrical components from overloads. Never remove a factory installed fuse or circuit breaker and replace with a high value device. If the added electrical device causes "fuse blow", or circuit breaker cycling, it indicates the total load is too high for the factory-installed circuit protection and requires revisions in the added circuit; not an increase in fuse or circuit breaker size. In this case, the device cannot be added directly to the circuit, but must be connected through a separate hang-on switch or relay of the correct capacity, using added wiring of the correct gauge. Failure to adopt this precaution will lead to switch contacts burning. The following wire table suggests wire gauges for various maximum current draws and will aid in the selection of the correct wire size. The current capacity of a given wire varies with temperature and type of insulation, but the following values are generally acceptable. If the total electrical load on the circuit, after the addition of electrical equipment, is less than the fuse protection in that circuit or less than the capacity of some limiting component (switch, relay, etc.), the items to be added can be connected directly to that circuit. The connection points and allowable loads are normally found in the owner's manual. Contact the OEM with any questions.

Appendix

Wire Gauge	Maximum Current Capacity (Crosslink Polythlene Copper Wire)
20	14 Amps
18	18 Amps
16	24 Amps
14	34 Amps
12	42 Amps
10	58 Amps
8	80 Amps
6	110 Amps

J1939/11 Data Link Detail

Recommended Cable Manufacturer	Cable Part Number	Round	J1939 (+) (PIN "A") Color	J1939 (-) (PIN "B") Color	J1939 (PIN "C") Shield
Champlain	23-00013-001	Yes	Yellow	Green	N/A
Champlain	23-00028-001	No	Yellow	Green	N/A
Raychem	2021D0311	No	Yellow	Green	N/A
Raychem	2021D0001	No	Yellow	Green	N/A
Raychem	2021D0301	Yes	Yellow	Green	N/A
BICC Brand-Rex	T-14945	Yes	Yellow	Green	N/A

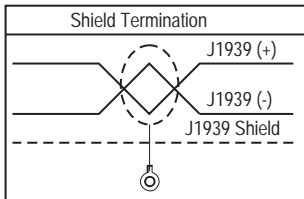

** If an additional wire is added to the drain for insertion into the connector, no shield terminal is used and the signal terminal quantity is 3.
If the drain wire is to be directly inserted into the connector, then a shield terminal is used and the signal terminal quantity is 2.

Ref.	Body	Signal Terminals (QTY)	Shield Terminal (QTY)	Wedge	Function
A	DT06-3S-P032	0462-201-1631 (3) **	0462-221-1631 (1) **	W3S-1939-P012	Through Connector
B	DT06-3S-P032	0462-201-1631 (3) **	0462-221-1631 (1) **	W3S-P012	Stub Connector
C	DT04-3P-P007	N/A	N/A	N/A	"T" Receptacle
D	DT04-3P-P006	N/A	N/A	N/A	120 Ohm Termination
E	DT04-3P-E008	0460-202-1631 (3) **	0460-247-1631 (1) **	W3P	ECU Receptacle
F	DT04-3P-LE08	0460-202-1631 (3) **	0460-247-1631 (1) **	W3P-1939	Flang Receptacle
G	DT06-3S-P006	N/A	N/A	N/A	120 Ohm Termination

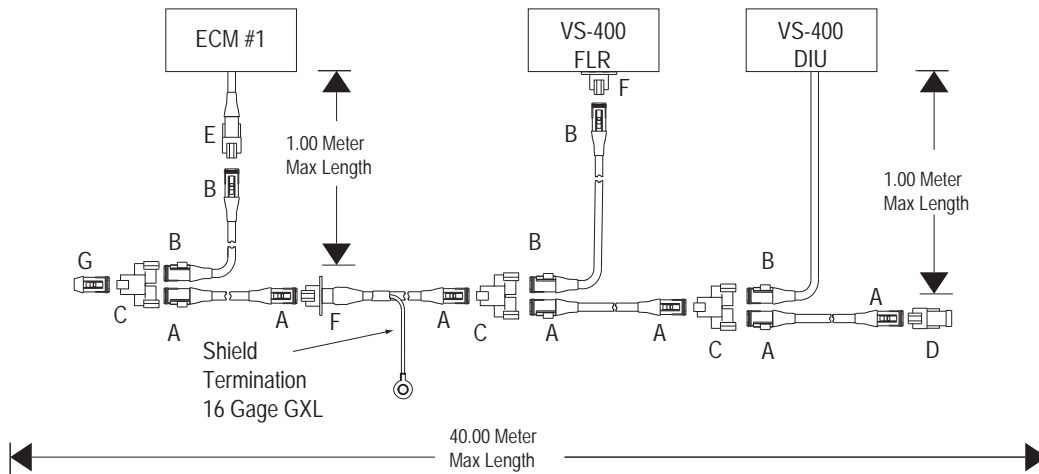

SAE J1939/11 Recommended Cable Termination Procedure

1. Remove cable outer jacket approximately 1" (25mm).
2. Remove foil from exposed wires to within 1/16" (2mm) from cable jacket.
3. Strip insulation from data wires .25" (7mm).
4. Attach extended wire barrel socket contact to the drain wire or attach adhesive filler solder sleeve and wire to drain wire per manufacturer's recommendations. For the solder sleeve option, cut the wire on the solder sleeve to a length of 1" (25mm) and strip the insulation back .25" (7mm).
5. Crimp the appropriate terminal on each data wire and solder sleeve wire or the extended socket per the manufacturer's recommendations.
6. Slide the adhesive filler shrink tube over the cable end.
7. Install the terminals into the connector body per the manufacturer's instructions.
8. Install the wedge in the front of the connector body per the manufacturer's instructions.
9. Apply the shrink tube to the end of the connector body per the manufacturer's instructions.

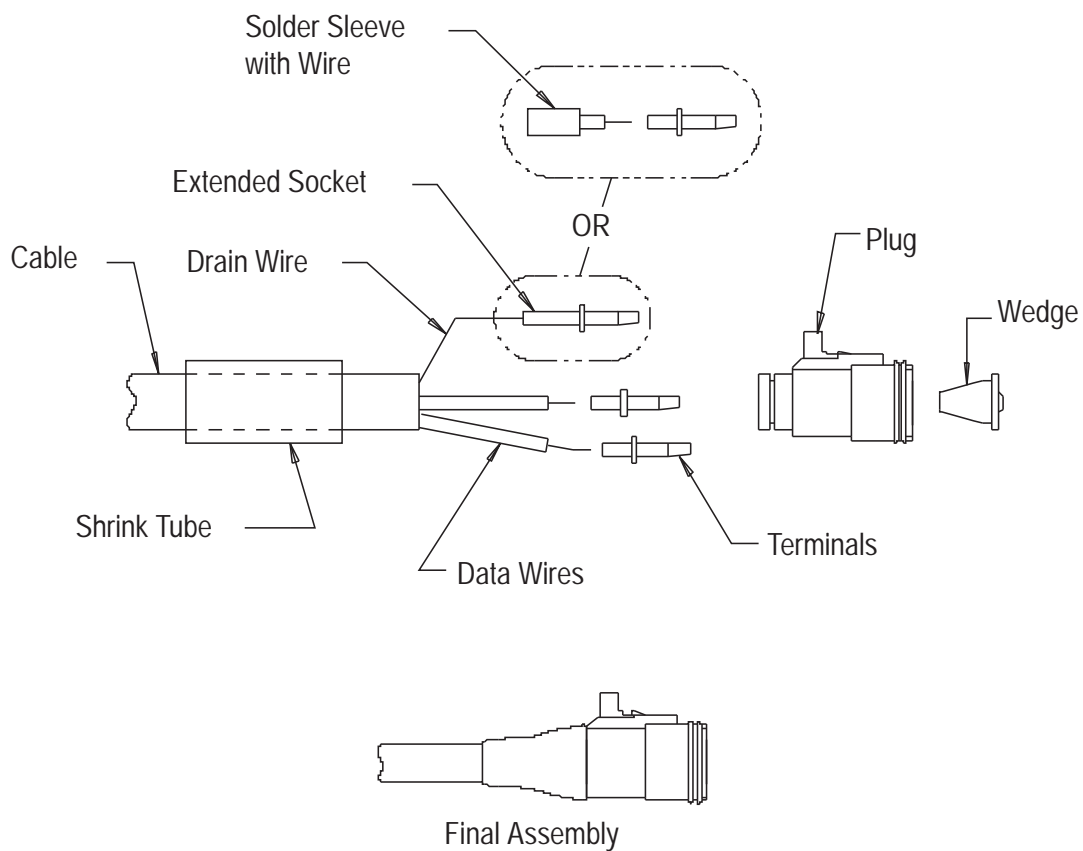

SAE J1939/11 Recommended Cable Splice Procedure

1. Remove cable outer jacket approximately 1-1/2" to 4" (40 to 100mm).
2. Remove foil shield from exposed wires to within 1/16" (2mm) from cable jacket.
3. Strip insulation from data wires .25" (7mm).
4. Attach X-link wire to drain wire with crimp slice per manufacturer's recommendation.
5. Slide adhesive filled shrink tube over crimp splice.
6. Slide adhesive filled shrink tube over cable end.

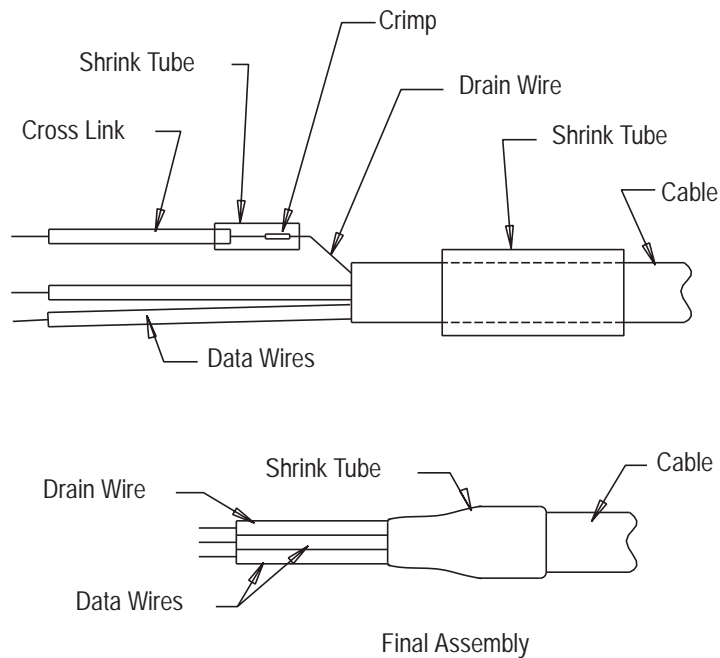

Existing Drain Wire Splice/Sealing Method

1. Remove cable outer jacket approximately 1-1/2" to 4" (40 to 100mm).
2. Remove foil shield from exposed wires to within 1/16" (2mm) from cable jacket.
3. Strip insulation from data wires .25" (7mm).
4. Crimp stub branch lines and drain wire to main backbone data lines and drain wire.
5. Cover each splice with insulation shrink tubing.
6. Wrap unshielded area with shielding material.
7. Apply adhesive filled shrink tube to splice junction.
8. For shield termination, crimp maximum 16 gauge GXL wire to drain wire.



J1939/15 (lite) Data Link Detail

Maximum 131 feet (40 meters) length.

Maximum 10 feet (3 meters) stub length.

Maximum 10 modules on segment.

Twisted pair (18 or 20 AWG) with 1 twist per inch.

120 Ohm terminating resistors must be used.

Connector at ECU is not defined.

The third pin for shield is not used in 'in-line' the T-connectors.

Recommended Cable Manufacturer	Cable Part Number	Round	J1939 (+) (PIN "A") Color	J1939 (-) (PIN "B") Color
Champlain	J1939/15	Yes	Yellow	Green

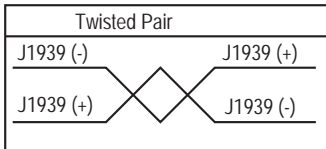

Ref.	Body	Signal Terminals (QTY)	Wedge	Function
A	DTM06-2S	0462-201-20141 (2) **	WM-2SB	Through Connector
B	DTM06-2S	0462-201-20141 (2) **	WM-2S	Stub Connector
C	DTM04-2P-P007	N/A	N/A	"T" Receptacle
D	DTM04-2P-EP10	N/A	WM-2PB	120 Ohm Termination
E	DTM04-2P	0460-202-20141 (2) **	WM-2P	ECU Receptacle
F	DTM04-2P	0460-202-20141 (2) **	WM-2PB	Through Receptacle
G	DTM06-2S-EP10	N/A	N/A	120 Ohm Termination

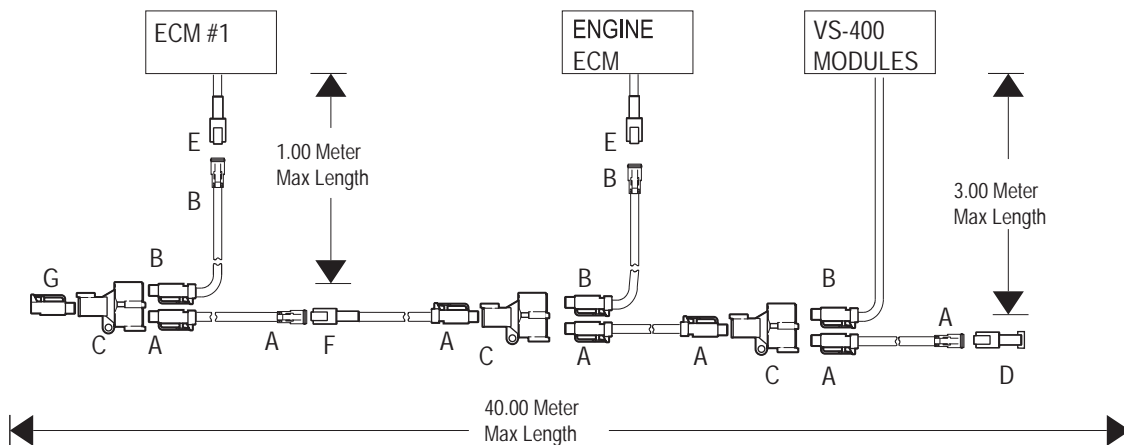

Wiring Schematics

Bendix™ SmartCruise® Adaptive Cruise Control and/or Collision Warning System

Using the OEM Integrated Dash as Display

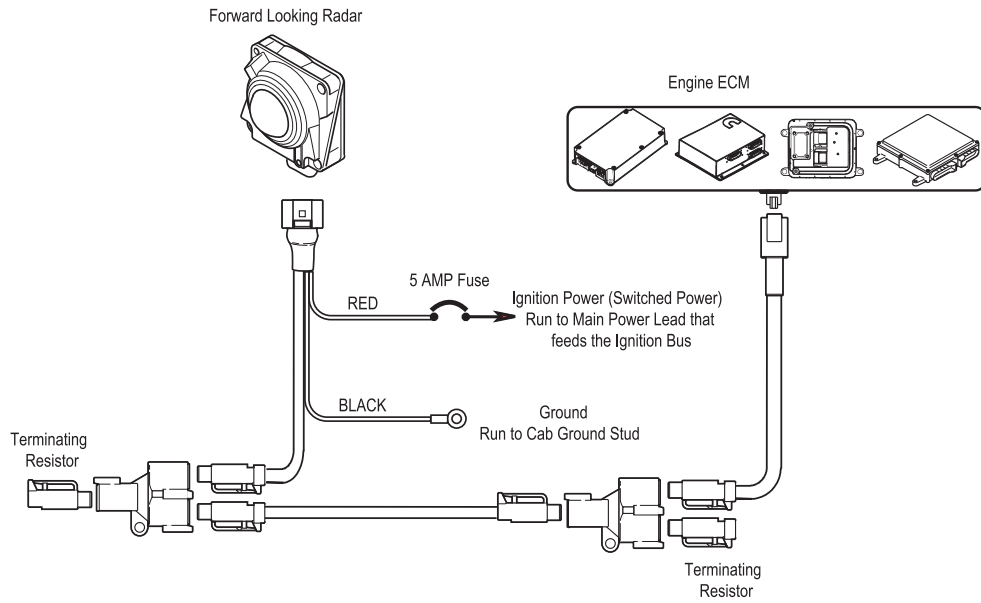

Bendix™ SmartCruise® Adaptive Cruise Control and/or Collision Warning System

Using the Driver Interface Unit as Display

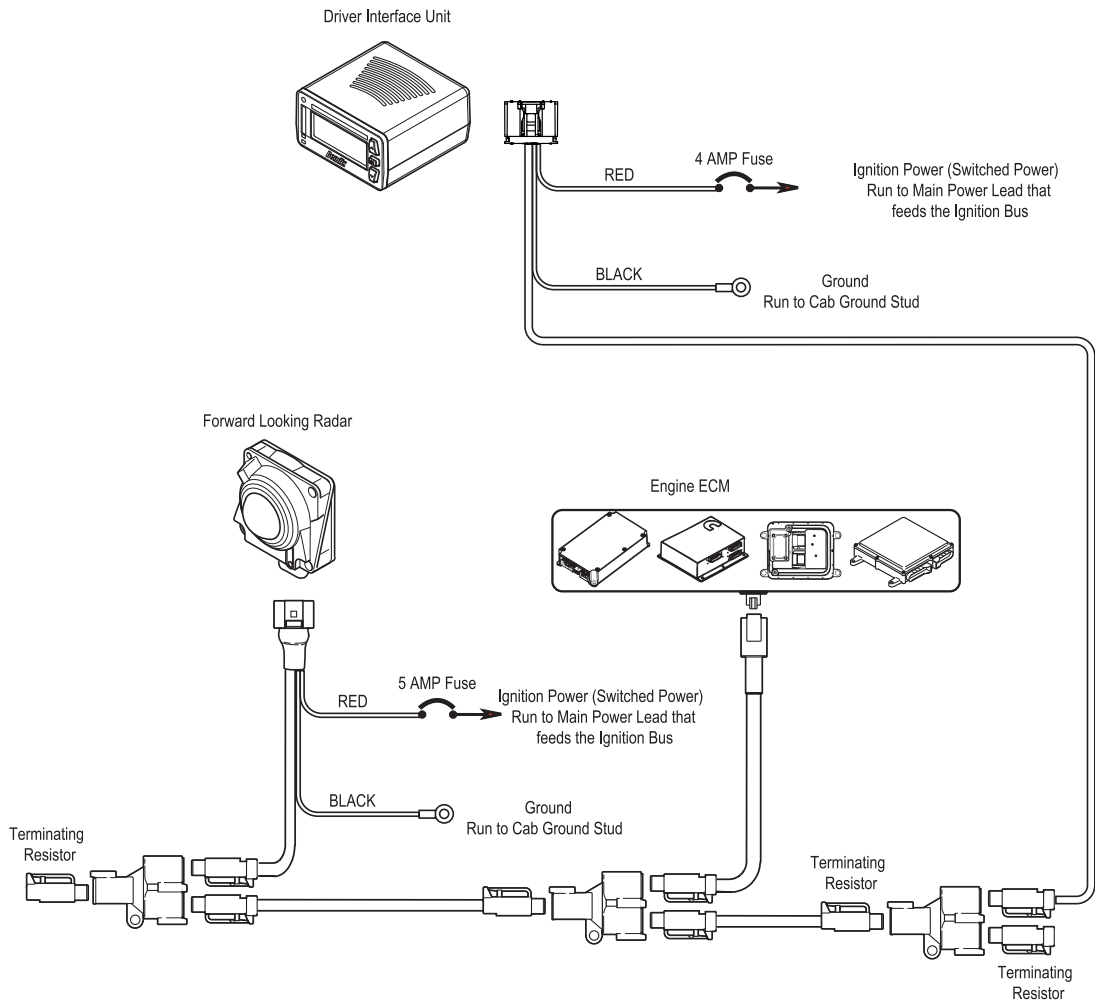

Collision Warning System with Side Object Detection

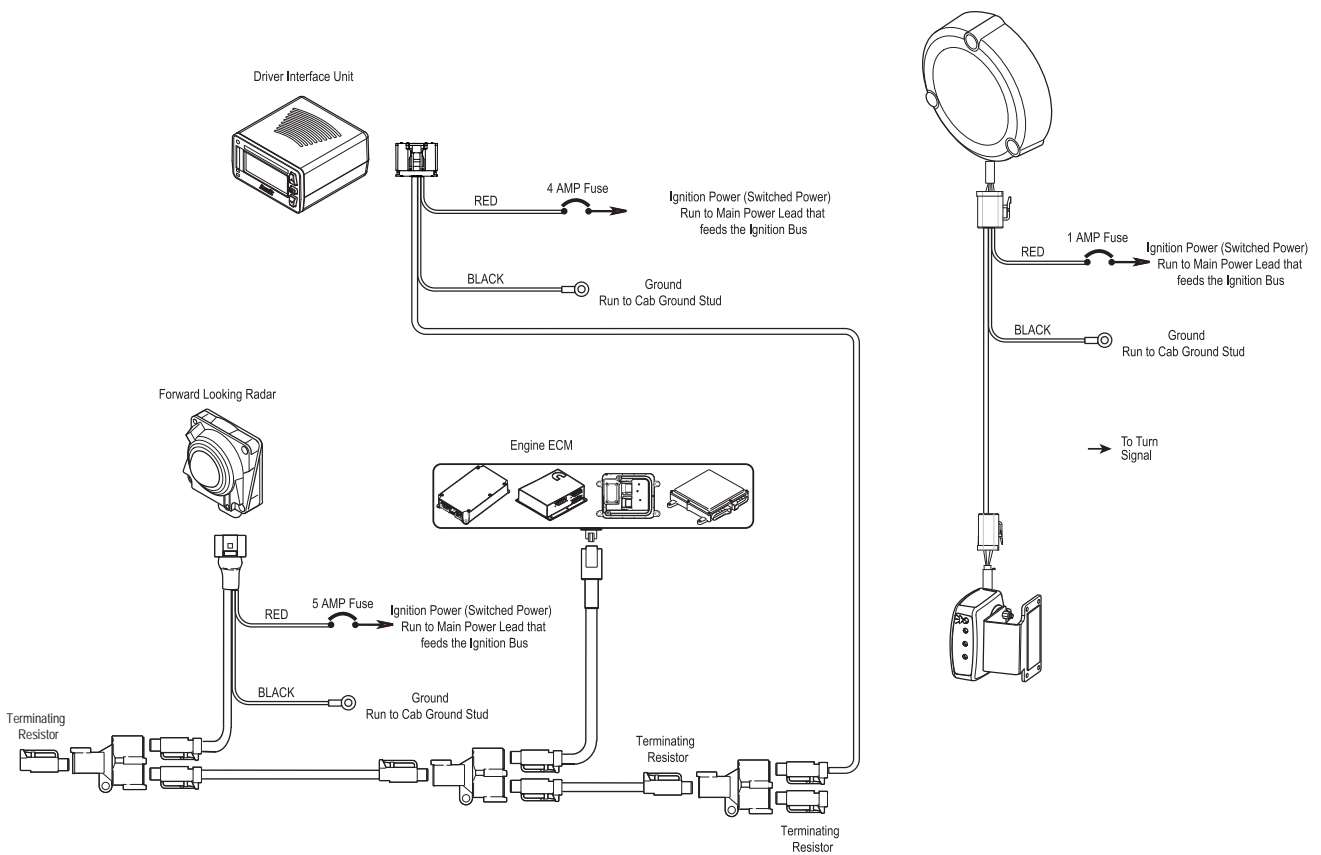

Connector Pin Descriptions

Forward Looking Radar

10-pin TRW Connector

PIN #	SIGNAL NAME	TYPE	INTERFACE LEVEL
1	NO_CONNECTION	-	-
2	NO_CONNECTION	-	-
3	J1939_SHIELD		TRUCK J1939 LINK
4	CAN_HI	-	TRUCK J1939 LINK
5	CAN_LO	-	TRUCK J1939 LINK
6	NO_CONNECTION	-	-
7	NO_CONNECTION	-	-
8	NO_CONNECTION	-	-
9	GROUND	POWER	CHASSIS GROUND
10	IGNITION	POWER	+12V SWITCHED

Driver Interface Unit

8-Pin Molex Connector

PIN #	SIGNAL NAME	TYPE	INTERFACE LEVEL
1	RIGHT_SPEAKER	O	SPEAKER DRIVER 4 OHM / 1 WATT
2	LEFT_SPEAKER	O	SPEAKER DRIVER 4 OHM / 1 WATT
3	BLACKOUT_INPUT / SPARE	I	TRI-STATE INPUT
4	BATTERY	POWER	+9-32VDC SWITCHED
5	GROUND	POWER	CHASSIS GROUND
6	CAN_LO		TRUCK J1939 LINK
7	CAN_HI		TRUCK J1939 LINK
8	SPARE_ANALOG	I	TRI-STATE INPUT

Side Sensor Display Unit

4-pin Deutsch Connector

PIN #	SIGNAL NAME	TYPE	INTERFACE LEVEL
1	POWER	I	+12V FROM SENSOR
2	GROUND	POWER	CHASSIS GROUND
3	COMMUNICATION	I	
4	TURN_SIGNAL	I	+12V

Side Sensor

6-pin Deutsch Connector

PIN #	SIGNAL NAME	TYPE	INTERFACE LEVEL
1	IGNITION	POWER	+12V SWITCHED
2	GROUND	POWER	CHASSIS GROUND
3	COMMUNICATION	O	
4	POWER	O	+12V
5	SODDU-GROUND	POWER	GROUND
6	NO CONNECTION	-	-

Vendor Contact Information

AMP/Tyco

Harrisburg, PA
Tel: 800.522.6752
<http://www.tycoelectronics.com/>

Champlain Cable Corporation

175 Hercules Drive
Colchester, Vermont 05446
Tel: 800.451.5162
<http://www.champcable.com/>

Deutsch

LADD Industries
4849 Hempstead Station Dr.
Kettering, OH 45429
Tel: 800.223.1236
<http://www.laddinc.com>

FEP

FAHRZEUGELEKTRIK PIRNA GmbH & CO. KG
Hugo-Küttner-Straße 8
01796 Pirna
Tel: +49 3501 514 0
http://www.fepz.de/en/e_index.html

Littelfuse World Headquarters

800 E. Northwest Highway
Des Plaines, IL 60016
Tel: 847.824.1188
Fax: 847.391.0894
<http://www.littelfuse.com>

Molex

2222 Wellington Court
Lisle, IL 60532-1682
Tel: 800.78MOLEX
<http://www.molex.com>

Packard

Delphi Connection Systems
5725 Delphi Drive
Mail Station 483.400.301
Troy, MI 48098
Tel: 800.610.4835
<http://www.delphisecure2.com/site/home/homemain.asp>

Packard Distributor

Power & Signal Group
World Headquarters
4670 Richmond Road
Suite 120
Cleveland, OH 44128
Tel: 800.722.5273 or 216.378.6600
<http://www.powerandsignal.com>

